



ADR-812

ANALOG ADDRESSABLE TWO-CHANNEL INPUT MODULE

Technical Manual

Manufacturer **TELEFIRE Fire & Gas Detectors LTD**
5 Halapid St.
P.O.B. 7036
Petach Tikva 49250
Israel

Tel:	++ 972 3 921 1955
Fax:	++ 972 3 921 1816
Email:	marketing@telefire.co.il
Web Site:	www.telefire.co.il

19 June 2003
Rev.: 1.11

General

The ADR-812 is a two-IDC monitor module that operates as an interface between the ADR-3000 addressable control panel and compatible two-wire conventional initiating devices. The two NFPA 72 Style C Initiating Device Circuits (IDCs) occupy two consecutive addresses.

The ADR-812 reports the following trouble events and conditions of the zone module: short-circuit, cutoff in the IDC loop and 24VDC input fault.

The ADR-812 has a 24VDC resettable power limited output. This output is interrupted upon Reset, in order to reset devices that were latched on alarm.

The optional 3-wire connection allows connecting detectors that have higher power consumption, such as gas detectors or beam detectors.

Compatibility

The ADR-812 can be connected to the following conventional Telefire detectors: TFH-220R; TFH-220F; TFI-330, and TFO-440. Other compliant devices may be approved by Telefire.

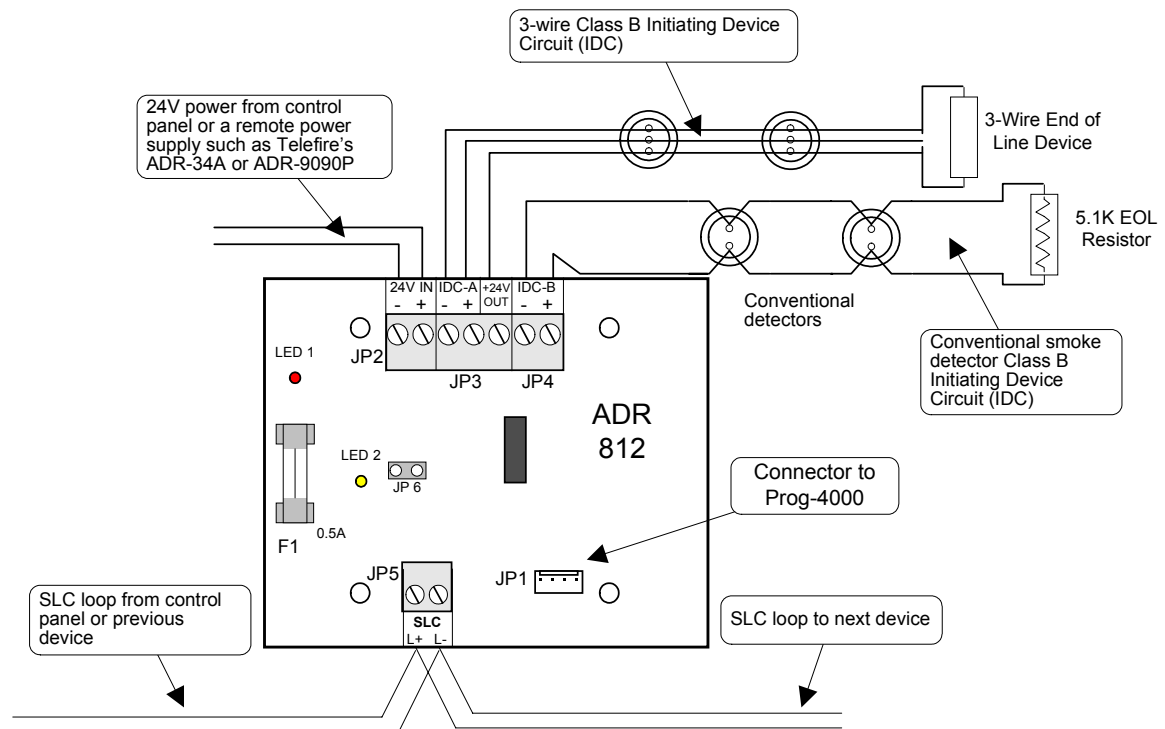

Figure 1: ADR-812 Two-zone conventional detector interface module.

Installation

Address Programming

The module's address should be programmed prior to installation by connecting the PROG-4000 unit to the connector JP1 (refer to the PROG-4000 manual for further details).

The monitor module can be programmed to an address number between 1 and 127. If two zones are connected, then two addresses should be programmed by removing the

jumper from JP6. The module will receive two consecutive address numbers. Select an address that is followed by a vacant one.

Mounting the ADR-812 in an AIB-800 Box

Follow these instructions if mounting the ADR-812 in an AIB-800 Analog Input / Output Module Box.

Mount the AIB-800 on a clean firm surface.

There are three mounting screw holes in the AIB-800 enclosure's base.

1. Mark the holes on the mounting surface according to figure 2.
2. Drill the appropriate holes.
3. Open the appropriate wiring knockout opening.
4. Screw the enclosure back to the surface.
5. Install the ADR-812 in the AIB-800 box.
6. Connect wiring according to instructions (see below).
7. Close the cover and tighten two screws through two holes under the knockout holes.
8. Write the appropriate addresses on the label on the back of the AIB-800.

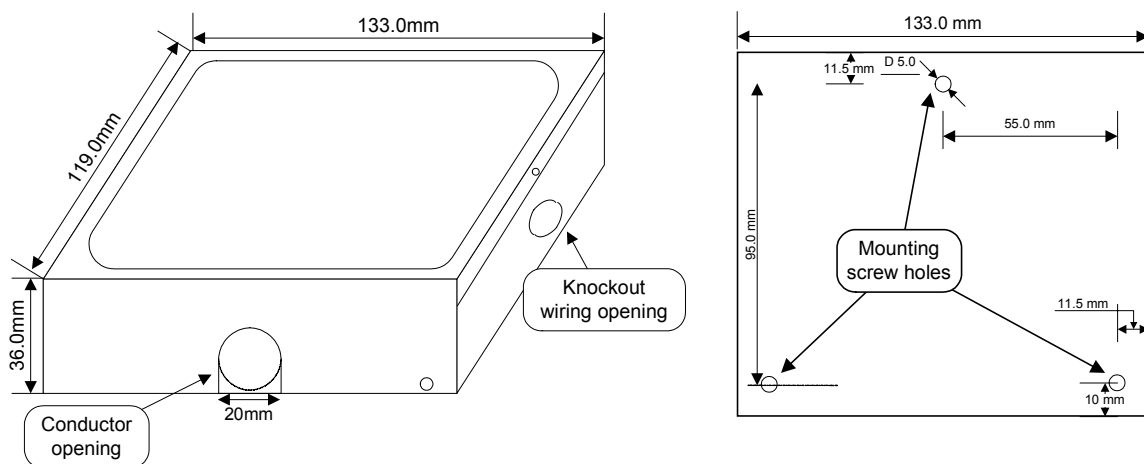

Figure 2: AIB-800 Box for Analog Addressable Input / Output Modules

Wiring

Note Notify the operator or the security personnel that the system will be temporary disconnected before adding an ADR-812 to an existing system. Disconnect all power sources (mains and battery) before adding devices to an existing system.

Use an anti-static ground wrist strap when handling any system circuits, to prevent static discharge to the modules.

Connect all wires according to marked polarity (see figure 1).

All wiring must conform to applicable local codes, ordinances and regulations.

Refer to the ADR-3000 Technical Manual for further details.

1. Connect the SLC loop wire to JP5 according to marked polarity (L+ Red, L- Black).
2. Connect the 24VDC from the power source to JP2.
3. If the ADR-812 will monitor a single IDC loop, leave jumper JP6 plugged in. If the ADR-812 will monitor two IDC loops remove jumper JP6. The ADR-812 will occupy two consecutive addresses.
4. Connect the first IDC loop to terminal JP3 (IDC-A) according to marked polarity.
5. Connect the second IDC loop (if there is a need for it) to terminal JP4 (IDC-B).
6. Connect the 5.1 K Ω (EOL) resistor to the last detector on the IDC loops.
7. The 24VDC resettable power limited output (24VOUT – JP3), is interrupted on Reset, in order to reset devices that turn to be latched on alarm. Only Telefire-approved detectors should be connected.

Status Indicating Lamps

The red LED LD1 continually flickers on each system communication request to one of the addresses of the module. At alarm mode of one of the IDC circuits, the red LED will latch on.

The yellow LED LD2 will start to flicker whenever a trouble mode occurs such as IDC short circuit, 24V input voltage fault, cut wire. The control panel will display the relevant trouble event.

A full description of a trouble event will be displayed on the control panel's screen as well.

Troubleshooting

Table 1 shows trouble events that may be displayed on the ADR-3000 control panel's screen, relevant to the ADR812 monitor module or a burned out fuse.

	Type of Malfunction	Possible Cause	Repair Actions
1	Trouble Fuse 24V	24V Fuse blown.	Locate the cause and repair.
2	Trouble short circuit	A short in the module's IDC loop.	Locate the cause and repair.
3	Trouble cut wire	Cutoff circuit in the IDC loop.	Locate the cause and repair.
4	Trouble 24V Low	Module's 24VDC input fault.	Check connections and power source.

Specification

Temperature:	32°F to 120°F (0°C to 49°C)
Relative Humidity:.....	10% to 93% non condensing
Dimensions:.....	133.0 X 119.0 X 36.0
SLC Current:.....	140 μ A Max (Standby)
.....	2.0 mA Max (Alarm)
Operating Voltage (supplied by ADR-3000)	20 V modulated
External power supply:	24 VDC nominal
Input Voltage.....	16.0-26.0 VDC
IDC Current	4.5 mA Max (Standby)
.....	40 mA Max (Alarm)
.....	50 mA Max (When IDC is shorted)
EOL Resistor:	5.1 K ohm nominal
Max 24V output current	0.5 A (protected by a 0.5 A fuse)

Specifications are subject to change without prior notice.

Certification

Telefire's ADR-812 Analog Addressable Input Interface has the following approvals:

- SI 1220 Approved
- EN 54 Approved