

# Shut Off Valves, Butterfly Valves

- D** Absperrarmaturen, Absperrklappe
- F** Vannes d'Arrêt, Vannes Papillon FM

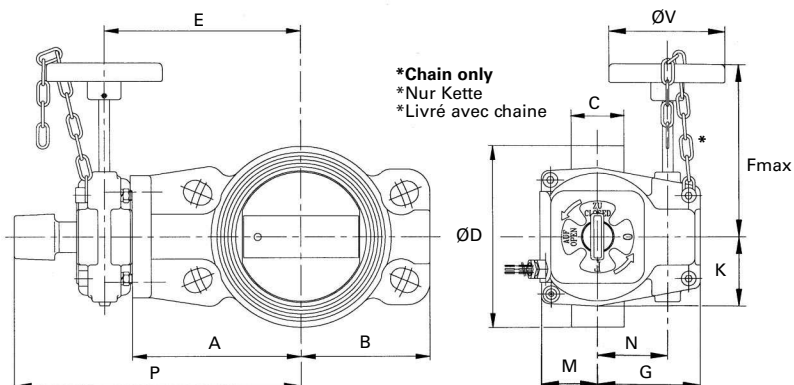
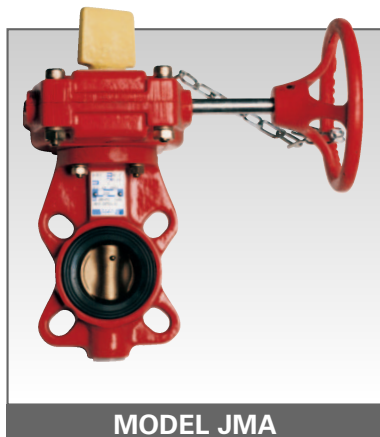

## Model JMA • Semi-Lug ANSI/PN10/PN16/Zwischenflanschführung mit Montageösen ANSI/PN10/PN16

Art. Nr. with Switch mit Schalter avec Contact	Art. Nr. without Switch ohne Schalter sans Contact	DN	A mm	B mm	C mm	ØD mm	E mm	F mm	G mm	K mm	M mm	N mm	P mm	ØV mm	kg	CE	VDS	LP/GB	FM	UL	VNI/PO	T/S/U	BM/OKF			
81219SC50	81219S50	50 2"	110	74	43	94	140	208	111	75	60	75	237	150	9.1	✓	✓	✓	✓	✓	✓	✓	✓	✓		
81219SC65	81219S65	65 2.1/2"	118	81	46	107	148	208	111	75	60	75	245	150	9.8	✓	✓	✓	✓	✓	✓	✓	✓	✓	✓	
81219SC80	81219S80	80 3"	125	93	46	126	155	208	111	75	60	75	252	150	10.2	✓	✓	✓	✓	✓	✓	✓	✓	✓	✓	✓
81219SC100	81219S100	100 4"	140	107	52	150	170	208	111	75	60	75	267	150	12.4	✓	✓	✓	✓	✓	✓	✓	✓	✓	✓	✓
81219SC125	81219S125	125 5"	160	122	56	179	190	208	111	75	60	75	287	150	14.2	✓	✓	✓	✓	✓	✓	✓	✓	✓	✓	✓
81219SC150	81219S150	150 6"	175	135	56	204	205	215	111	75	60	75	303	225	18.1	✓	✓	✓	✓	✓	✓	✓	✓	✓	✓	✓
81219SC200	81219S200	200 8"	206	170	60	259	236	215	111	75	60	75	333	225	22	✓	✓	✓	✓	✓	✓	✓	✓	✓	✓	✓
81119SC250	81119S250	250 10"	247	200	68	313	298	276	179	138	104	132	376	300	43	✓	✓	✓	✓	✓	✓	✓	✓	✓	✓	✓
81119SC300	81119S300	300 12"	277	233	78	369	328	276	179	138	104	132	406	300	51	✓	✓	✓	✓	✓	✓	✓	✓	✓	✓	✓

Max. 12.1 Bar [175 Psi]

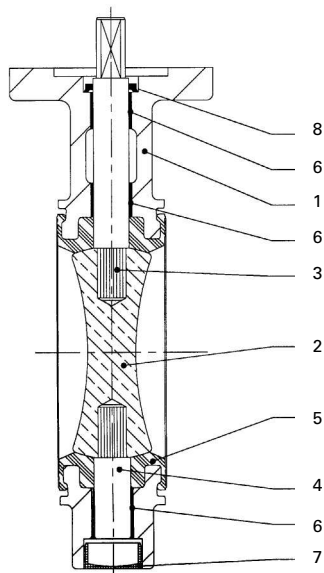

## Parts List/Bauteil-Spezifikation/Caractéristiques Techniques

Nr.	Description Umschreibung Description	Material Material Matériau
1	Body (wafer)/Körper(Zw.Fi)/Corps	Ductile Iron/Duktiler Guß/Fonte FGS 400.15
2	Disc (DN50-DN200)/Klappe50-200/Papillon DN50-200 Disc (DN250-DN300)/Klappe250-300/Papillon DN250-300	Brass/Rotguß/Laiton Ductile Iron/Duktiler Guß/Fonte ductile
3	Control Shaft/Antriebswelle/Arbre	Stainless Steel/Edelstahl/Acier inoxydable Z20C13 traité
4	Spindle/Spindel/Axe	Stainless Steel/Edelstahl/Acier inoxydable Z20C13 traité
5	Seat/Sitz/Manchette	EPDM/EPDM/EPDM
6	Bearings/Lager/Paliers auto-lubrifiants	PTFE on Steel/PTFE Stahl/Bronze fritté avec PFTE sur acier étamé
7	Protection plug/Schutzstopf./Bouchon de protection	Polyethylene/Polyethylen/Polyéthylène
8	Chevron Seal/Dichtung/Joint à lèvres	Nitrile/Nitril/Nitrile
9	ID Plate/Typenschild/Plaque d'identification	Stainless Steel/Edelstahl/Acier inoxydable

TYCEGFFP-11/03 Tyco reserves the right to change the contents without notice