

Series ELO-231B — 11.2 K-factor Upright and Pendent Sprinklers Standard Response, Standard Coverage

General Description

The 11.2 K-factor, Series ELO-231B, Standard Response, Standard Coverage, Upright and Pendent Sprinklers (Ref. Figure 1) are automatic sprinklers of the frangible bulb type. They are "standard response - spray sprinklers" that produce a hemispherical water distribution pattern below the deflector.

The 11.2 K-factor, ELO-231B Sprinklers were subjected to full scale, high-piled storage, fire tests to qualify their use in lieu of 5.6 or 8.0 K-factor standard spray sprinklers for the protection of high-piled storage.

Higher flow rates can be achieved at much lower pressures with the 11.2 K-factor, ELO-231B Sprinklers — making their use highly advantageous in high density applications, such as the protection of high-piled storage.

Wax or lead coatings can be used to extend the life of the copper alloy components used in Series ELO-231B sprinklers beyond that which would otherwise be obtained when exposed to corrosive atmospheres. Although wax, lead, and polyester coated sprinklers have passed the standard corrosion tests of the applicable approval agencies, the testing is not repre-

sentative of all possible corrosive atmospheres. Consequently, it is recommended that the end user be consulted with respect to the suitability of these corrosion resistant coatings for any given corrosive environment. The effects of ambient temperature, concentration of chemicals, and gas/chemical velocity, should be considered, as a minimum, along with the corrosive nature of the chemical to which the sprinklers will be exposed.

An upright intermediate level version of the Series ELO-231B Sprinklers for in-rack applications can be obtained by utilizing the Series ELO-231B Upright Sprinkler with the WSG-2 Guard & Shield, and a pendent intermediate level version of the Series ELO-231B Sprinklers can be obtained by utilizing the Series ELO-231B Pendent Sprinkler with the WS-2 Shield. If there is a possibility of the pendent intermediate level version being exposed to mechanical damage, a G-2 Guard can be added.

WARNINGS

The 11.2 K-factor, Series ELO-231B Upright and Pendent Sprinklers described herein must be installed and maintained in compliance with this document, as well as with the applicable standards of the National Fire Protection Association, in addition to the standards of any other authorities having jurisdiction. Failure to do so may impair the performance of these devices.

The owner is responsible for maintaining their fire protection system and devices in proper operating condition. The installing contractor or manufacturer should be contacted with any questions.

Installation of Series ELO-231B Pendent Sprinklers in recessed escutcheons will void all sprinkler warranties, as well as possibly void the sprinkler's Approvals and/or Listings.



IMPORTANT

Always refer to Technical Data Sheet TFP700 for the "INSTALLER WARNING" that provides cautions with respect to handling and installation of sprinkler systems and components. Improper handling and installation can permanently damage a sprinkler system or its components and cause the sprinkler to fail to operate in a fire situation or cause it to operate prematurely.

| TYPE | TEMPERATURE | BULB LIQUID | SPRINKLER FINISH | | | | |
|------------------------------|-------------|-------------|------------------|---------------|-------------|------------|------------------|
| | | | NATURAL BRASS | CHROME PLATED | LEAD COATED | WAX COATED | WAX OVER LEAD |
| UPRIGHT (TY5151 & TY5851) | 155°F/68°C | Red | 1, 2, 3, 4 | | | 3 | |
| | 200°F/93°C | Green | | | | 3 | 3 ^(a) |
| | 286°F/141°C | Blue | | | | | |
| PENDENT (TY5251) | 155°F/68°C | Red | 1, 2, 3, 4 | | | 3 | |
| | 200°F/93°C | Green | | | | 3 | 3 ^(a) |
| | 286°F/141°C | Blue | | | | | |

NOTES:

1. Listed by Underwriters Laboratories, Inc. (UL Listed).
2. Listed by Underwriters Laboratories, Inc. for use in Canada (C-UL Listed).
3. Approved by Factory Mutual Research Corporation (FM Approved).
4. Approved by the City of New York under MEA 291-04-E.

(a). FM Approved for a maximum ceiling temperature of 150°F/66°C.

TABLE A
LABORATORY LISTINGS AND APPROVALS
FOR 11.2 K-FACTOR SERIES ELO-231B UPRIGHT AND PENDENT SPRINKLERS
(Refer to the Design Criteria Section)

Model/Sprinkler Identification Numbers

TY5151 - Upright 11.2K, 3/4" NPT
TY5251 - Pendent 11.2K, 3/4" NPT
TY5851 - Upright 11.2K, 1/2" NPT

TY5151 is a redesignation for C5151.

TY5251 is a redesignation for C5251, G1871, and S2531.

TY5851 is a redesignation for C5851.

Technical Data

Approvals

UL and C-UL Listed. FM and NYC Approved. (Refer to Table A for complete approval information including corrosion resistant status. The approvals apply to the service conditions indicated in the Design Criteria section.)

Maximum Working Pressure

175 psi (12,1 bar)

Discharge Coefficient

$K = 11.2 \text{ GPM/psi}^{1/2}$
(161,4 LPM/bar^{1/2})

Temperature Ratings

Refer to Table A

Finishes

Refer to Table A

Physical Characteristics

Frame Bronze
Cap Bronze
Sealing Assembly
. Beryllium Nickel w/Teflon†
Bulb (5 mm dia.) Glass
Compression Screw Bronze
Deflector Bronze

† Registered trademark of DuPont.

Design Criteria

UL and C-UL Listing Requirements

The 11.2 K-factor, Model ELO-231B (TY5151, TY5251 & TY5851) Sprinklers are to be installed in accordance with NFPA 13 standard sprinkler position and area/density flow calculation requirements for light, ordinary, or extra hazard occupancies with a minimum residual (flowing) pressure of 7 psi (0,5 bar) in wet or dry pipe sprinkler systems, or they are to be installed in accordance with NFPA 13 standard sprinkler position and area/density flow calculation requirements for high piled storage occupancies (solid piled, palletized, rack storage, bin box, and shelf storage including but not limited to Class I-IV and Group A plastics) with a minimum residual (flowing) pressure of 10 psi (0,7 bar) for wet or dry pipe systems.

The following example is typical of the type of arrangement permitted by NFPA 13. For all combinations of lesser and greater building heights, lesser and greater storage heights, storage arrangements, commodity classifications, and lesser or greater required design densities, refer to NFPA 13 for specifics.

Example: NFPA 13 provides ceiling only protection (i.e., no in-rack sprinklers) criteria using open frame (i.e. no solid shelves) single, double, multiple-row, or portable rack storage (without

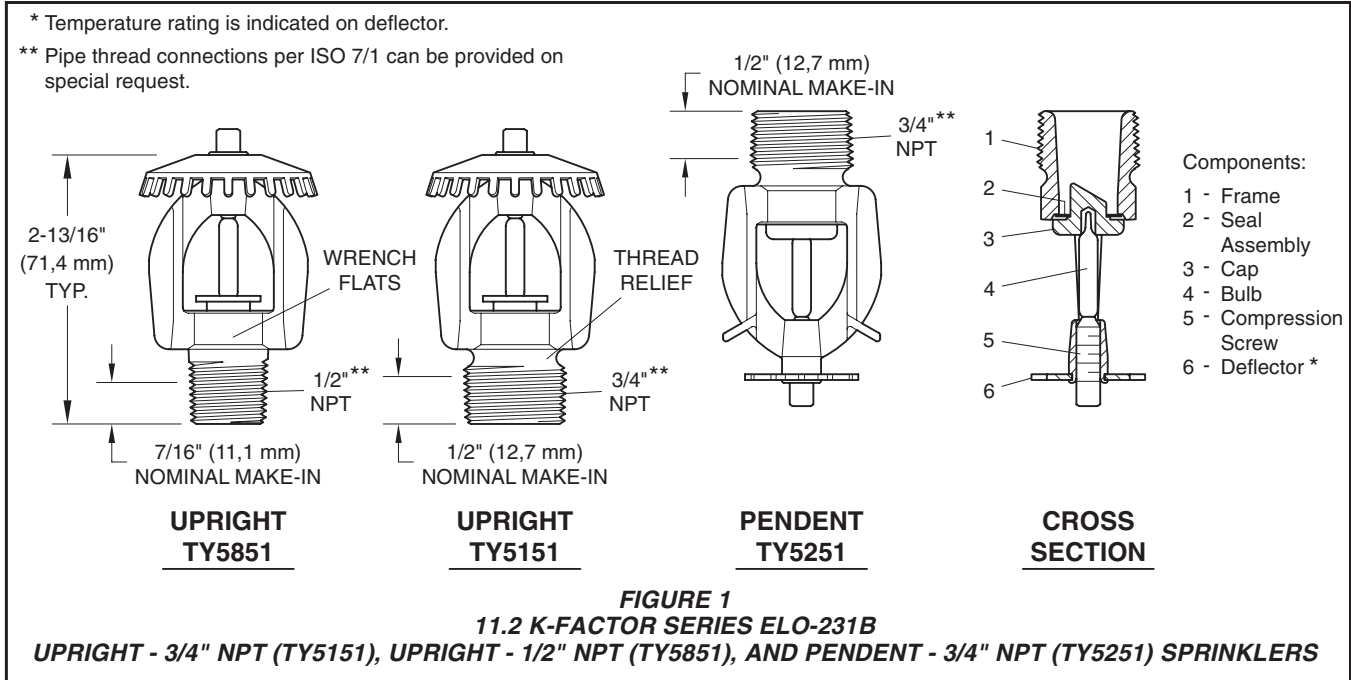

the need for in-rack sprinkler protection) of cartoned or uncartoned unexpanded Group A or B plastics, or, cartoned expanded Group A or B plastics, with:

- a storage height of up to 20 feet (6,1 m);
- a maximum ceiling height of 27 feet (8,2 m);
- a minimum deflector to top of storage clearance of 18 inches (457 mm);
- a minimum design density of 0.60 gpm/ft² (24,4 mm/min);
- a minimum residual (flowing) pressure of 10 psi (0,7 bar);
- a minimum design area of 2000 ft² (186 m²) for wet systems or 2600 ft² (242 m²) for dry pipe systems

FM Approval Requirements

The 11.2 K-factor, Model ELO-231B (TY5151, TY5251 & TY5851) Sprinklers are to be installed in accordance with the applicable "control mode density/area" guidelines provided by Factory Mutual. (FM guidelines may differ from UL and C-UL Listing criteria.)

Operation

The glass bulb contains a fluid that expands when exposed to heat. When the rated temperature is reached, the fluid expands sufficiently to shatter the glass bulb, allowing the sprinkler to activate and water to flow.

Installation

The Series ELO-231B Sprinklers must be installed in accordance with the following instructions:

NOTES

Do not install any bulb type sprinkler if the bulb is cracked or there is a loss of liquid from the bulb. With the sprinkler held horizontally, a small air bubble should be present. The diameter of the air bubble is approximately 1/16 inch (1,6 mm) for the 155°F/68°C to 3/32 inch (2,4 mm) for the 286°F/141°C temperature ratings.

A leak tight 3/4 inch NPT sprinkler joint should be obtained with a torque of 10 to 20 ft.lbs. (13,4 to 26,8 Nm). A maximum of 30 ft.lbs. (40,7 Nm) of torque is to be used to install sprinklers with 3/4 NPT connections. A leak tight 1/2 inch NPT sprinkler joint should be obtained with a torque of 7 to 14 ft.lbs. (9,5 to 19,0 Nm). A maximum of 21 ft.lbs. (28,5 Nm) of torque may be used to install sprinklers with 1/2 NPT connections. Higher levels of torque may distort the sprinkler inlet and cause leakage or impairment of the sprinkler.

Do not attempt to make-up for insuffi-

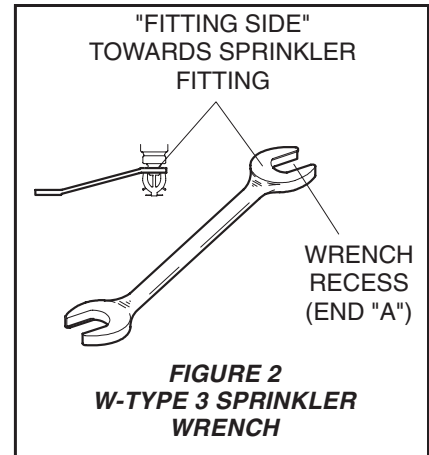

cient adjustment in the escutcheon plate by under- or over-tightening the sprinkler. Readjust the position of the sprinkler fitting to suit.

The **Series ELO-231B Upright and Pendent Sprinklers** must be installed in accordance with the following instructions.

Step 1. Pendent sprinklers are to be installed in the pendent position, and upright sprinklers are to be installed in the upright position.

Step 2. With pipe thread sealant applied to the pipe threads, hand tighten the sprinkler into the sprinkler fitting.

Step 3. Tighten the sprinkler into the sprinkler fitting using only the W-Type 3 Sprinkler Wrench (Ref. Figure 2), except that an 8 or 10 inch adjustable Crescent wrench is to be used for wax coated sprinklers. With reference to

Figure 1, the W-Type 3 Sprinkler Wrench or the adjustable Crescent wrench, as applicable is to be applied to the wrench flats.

When installing wax coated sprinklers with the adjustable Crescent wrench, additional care needs to be exercised to prevent damage to the wax coating on the sprinkler wrench flats or frame arms and, consequently, exposure of bare metal to the corrosive environment. The jaws of the wrench should be opened sufficiently wide to pass over the wrench flats without damaging the wax coating. Before wrench tightening the sprinkler, the jaws of the wrench are to be adjusted to just contact the sprinkler wrench flats. After wrench tightening the sprinkler, loosen the wrench jaws before removing the wrench.

After installation, the sprinkler wrench flats and frame arms must be inspected and the wax coating retouched (repaired) whenever the coating has been damaged and bare metal is exposed. The wax coating on the wrench flats can be retouched by gently applying a heated 1/8 inch diameter steel rod to the areas of wax that have been damaged, to smooth it back over areas where bare metal is exposed.

NOTES

Only retouching of the wax coating applied to the wrench flats and frame arms is permitted, and the retouching is to be performed only at the time of the initial sprinkler installation.

The steel rod should be heated only to the point at which it can begin to melt the wax, and appropriate precautions need to be taken, when handling the heated rod, in order to prevent the installer from being burned.

If attempts to retouch the wax coating with complete coverage are unsuccessful, additional wax can be ordered in the form of a wax stick (the end of which is color coded). Only the correct color coded wax is to be used, and retouching of wrench flats and frame arms is only permitted at the time of initial sprinkler installation. With the steel rod heated as previously described, touch the rod to the area requiring additional wax with the rod angled downward, and then touch the wax stick to the rod approximately one-half inch away from the area requiring retouching. The wax will melt and run down onto the sprinkler.

Care and Maintenance

Series ELO-231B Sprinklers must be maintained and serviced in accordance with the following instructions:

NOTES

Before closing a fire protection system control valve for maintenance work on the fire protection system that it controls, permission to shut down the affected fire protection system must be obtained from the proper authorities and all personnel who may be affected by this action must be notified.

Sprinklers that are found to be leaking or exhibiting visible signs of corrosion must be replaced.

Automatic sprinklers must never be painted, plated, coated or otherwise altered after leaving the factory. Modified sprinklers must be replaced. Sprinklers that have been exposed to corrosive products of combustion, but have not operated, should be replaced if they cannot be completely cleaned by wiping the sprinkler with a cloth or by brushing it with a soft bristle brush.

Care must be exercised to avoid damage to the sprinklers — before, during, and after installation. Sprinklers damaged by dropping, striking, wrench twist/slippage, or the like, must be replaced. Also, replace any sprinkler that has a cracked bulb or that has lost liquid from its bulb (ref. Installation Section Note).

Frequent visual inspections are recommended to be initially performed for corrosion resistant sprinklers, after the installation has been completed, to verify the long term potential integrity of the sprinkler coatings. Thereafter, annual inspections per NFPA 25 should suffice; however, instead of inspecting from the floor level, a random sampling of close-up visual inspections should be made, so as to better determine the exact sprinkler condition and the long term integrity of the corrosion resistant coating, as it may be affected by the corrosive conditions present.

The owner is responsible for the inspection, testing, and maintenance of their fire protection system and devices in compliance with this document, as well as with the applicable standards of the National Fire Protection Association (e.g., NFPA 25), in addition to the standards of any other authorities having jurisdiction. The installing contractor or sprinkler manufacturer should be contacted relative to any questions.

It is recommended that automatic sprinkler systems be inspected, tested, and maintained by a qualified Inspection Service in accordance with local requirements and/or national code.

Limited Warranty

Products manufactured by Tyco Fire Products are warranted solely to the original Buyer for ten (10) years against defects in material and workmanship when paid for and properly installed and maintained under normal use and service. This warranty will expire ten (10) years from date of shipment by Tyco Fire Products. No warranty is given for products or components manufactured by companies not affiliated by ownership with Tyco Fire Products or for products and components which have been subject to misuse, improper installation, corrosion, or which have not been installed, maintained, modified or repaired in accordance with applicable Standards of the National Fire Protection Association, and/or the standards of any other Authorities Having Jurisdiction. Materials found by Tyco Fire Products to be defective shall be either repaired or replaced, at Tyco Fire Products' sole option. Tyco Fire Products neither assumes, nor authorizes any person to assume for it, any other obligation in connection with the sale of products or parts of products. Tyco Fire Products shall not be responsible for sprinkler system design errors or inaccurate or incomplete information supplied by Buyer or Buyer's representatives.

IN NO EVENT SHALL TYCO FIRE PRODUCTS BE LIABLE, IN CONTRACT, TORT, STRICT LIABILITY OR UNDER ANY OTHER LEGAL THEORY, FOR INCIDENTAL, INDIRECT, SPECIAL OR CONSEQUENTIAL DAMAGES, INCLUDING BUT NOT LIMITED TO LABOR CHARGES, REGARDLESS OF WHETHER TYCO FIRE PRODUCTS WAS INFORMED ABOUT THE POSSIBILITY OF SUCH DAMAGES, AND IN NO EVENT SHALL TYCO FIRE PRODUCTS' LIABILITY EXCEED AN AMOUNT EQUAL TO THE SALES PRICE.

THE FOREGOING WARRANTY IS MADE IN LIEU OF ANY AND ALL OTHER WARRANTIES EXPRESS OR IMPLIED, INCLUDING WARRANTIES OF MERCHANTABILITY AND FITNESS FOR A PARTICULAR PURPOSE.

Ordering Procedure

A Part Number (P/N) is not specified when ordering sprinklers with thread connections per ISO 7/1.

Contact your local distributor for availability.

Sprinkler Assemblies

with NPT Thread Connection:
Specify: (specify SIN), 11.2 K-factor, (specify temperature rating), Series ELO-231B Standard Response (specify Pendent or Upright) Sprinkler with (specify finish), P/N (specify from Table B).

Sprinkler Wrench:

Specify: W-Type 3 Sprinkler Wrench, P/N 56-895-1-001.

Wax Sticks: (for retouching wrench damaged wax coating)

Specify: (Specify color) color coded Wax Stick for retouching (specify temperature rating) temperature rated Series ELO-231B Sprinklers, P/N (specify).

Red for 155°F..... P/N 56-065-1-155
Blue for 200°F and
286°F..... P/N 56-065-1-286

NOTES

Each wax stick is suitable for retouching up to twenty-five sprinklers.

The wax used for 286°F sprinklers is the same as for 200°F sprinklers, and, therefore, the 286°F sprinkler is limited to the same maximum ceiling temperature as the 200°F sprinkler (i.e., 150°F).

P/N 50 — XXX — X — XXX

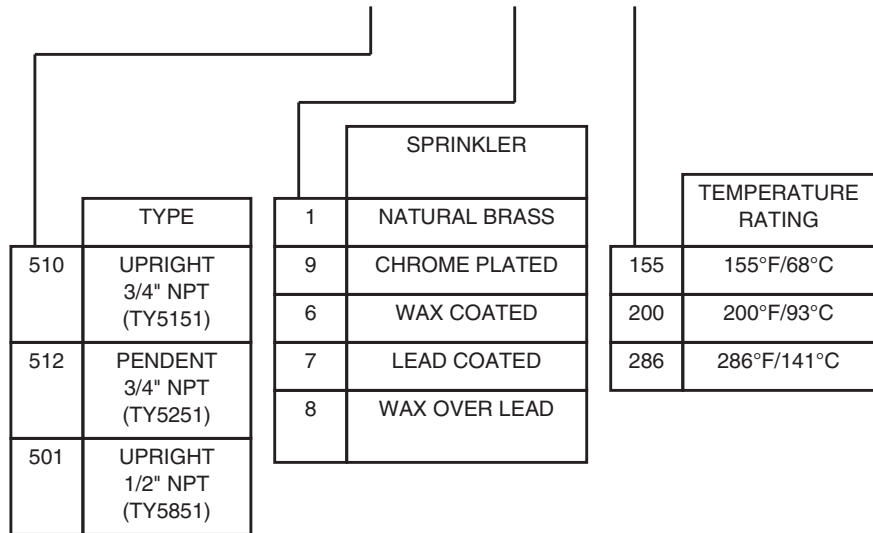

TABLE B
PRODUCT SYMBOL NUMBER SELECTION
11.2 K-FACTOR SERIES ELO-231B
STANDARD RESPONSE UPRIGHT AND PENDENT SPRINKLERS

