

## Model ESFR-17 Early Suppression Fast Response Upright Sprinklers 16.8 K-factor

### General Description

The Model ESFR-17 Upright Sprinklers (Ref. Figure 1) are "Early Suppression Fast Response Sprinklers" having a nominal K-factor of 16.8. They are suppression mode sprinklers that are especially advantageous as a means of eliminating in-rack sprinklers, when protecting rack storage.

The Model ESFR-17 is primarily designed for use in ceiling only sprinkler systems (i.e. no in-rack sprinklers) for the protection of storage heights of most encapsulated or non-encapsulated common materials including cartoned unexpanded plastics of up to 30 ft. (9,1 m) with ceiling heights to 35 ft. (10,7 m), as well as cartoned expanded plastics up to 25 ft. (7,6 m) with ceiling heights to 30 ft. (9,1 m). In addition, the protection of some storage arrangements of rubber tires and roll paper can be considered.

The ESFR-17 Upright Sprinklers provide the system designer with an upright option over the traditional pendant type ESFR sprinklers. The offering of a 16.8 K-factor optimizes hydraulic design when considering upright ESFR sprinklers. These features offer flexibility when sizing the system piping, as well as positioning the system piping with respect to the ceiling.

#### IMPORTANT

Always refer to Technical Data Sheet TFP700 for the "INSTALLER WARNING" that provides cautions with respect to handling and installation of sprinkler systems and components. Improper handling and installation can permanently damage a sprinkler system or its components and cause the sprinkler to fail to operate in a fire situation or cause it to operate prematurely.

#### WARNINGS

The Model ESFR-17 Upright Sprinklers described herein must be installed and maintained in compliance with this document, as well as with the applicable standards of the National Fire Protection Association, in addition to the standards of any other authorities having jurisdiction (e.g., FM Global). **Failure to do so may impair the performance of these devices.**

The owner is responsible for maintaining their fire protection system and devices in proper operating condition. The installing contractor or sprinkler manufacturer should be contacted with any questions.

### Sprinkler Identification Numbers

SIN TY7126 - (Upright K=16.8)

### Technical Data

#### Approvals

FM Approved.

#### Maximum Working Pressure

175 psi (12,1 bar)

#### Pipe Thread Connection

3/4 inch NPT or ISO 7-R3/4

#### Discharge Coefficient

K = 16.8 GPM/psi<sup>1/2</sup>  
(241,9 LPM/bar<sup>1/2</sup>)

#### Temperature Ratings

165°F/74°C or 214°F/101°C

#### Finish

Natural Brass

#### Physical Characteristics

Frame . . . . . Bronze  
Deflector . . . . . Copper  
Compression Screw . . . . .  
. . . . . Stainless Steel  
Hook . . . . . Monel



Strut . . . . . Monel  
Link Assembly . . . . Solder, Nickel  
Button . . . . . Brass  
Sealing Assembly . . . . .  
. . . . . Beryllium Nickel w/Teflon\*  
Ejection Spring . . . . . Inconel  
Deflector Nut . . . . . Brass

\*Registered trademark of DuPont.

#### Patents

U.S.A. Patent Numbers:  
4,580,729 5,829,532  
6,336,509  
Patents pending.

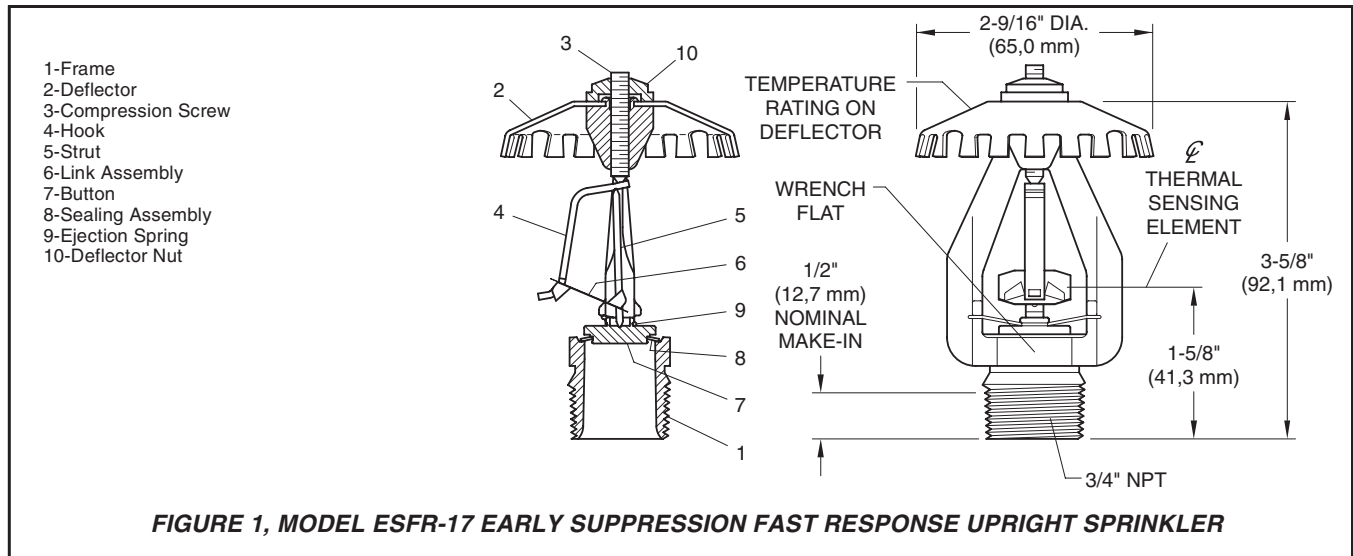

FIGURE 1, MODEL ESFR-17 EARLY SUPPRESSION FAST RESPONSE UPRIGHT SPRINKLER

## Design Criteria

### NOTE

The National Fire Protection Association (NFPA) and FM Global (FM) provide installation standards that must be used to properly design an automatic sprinkler system utilizing Early Suppression Fast Response (ESFR) Sprinklers. The guidelines provided by NFPA and FM may differ; consequently, the appropriate standard must be used for a given installation.

The following data sheets describe the ESFR Sprinklers offered by Tyco Fire Products:

**TFP312** — Model ESFR-25 (TY9226), K=25.2 Pendent Sprinkler

**TFP315** — Model ESFR-17 (TY7226), K=16.8 Pendent Sprinkler

**TFP316** — Model ESFR-17 (TY7126), K=16.8 Upright Sprinkler

**TFP318** — Model ESFR-1 (TY6226), K=14.0 Pendent Sprinkler

The following general guidelines provided for ESFR Sprinklers offered by Tyco Fire Products may be used for a quick reference to help select the appropriate Tyco Fire Products' ESFR Sprinkler:

### NOTE

In all cases, the appropriate NFPA or FM installation standard must be referenced to assure applicability and to obtain complete installation guidelines, since the following general guidelines are not intended to provide complete installation criteria.

### GENERAL GUIDELINES

**System Type:** Wet pipe system.

**Roof Construction:** Unobstructed or obstructed construction. For example: smooth ceiling, bar joists, beam and girder, etc.

### NOTE

Where the depths of the solid structural members (beams, stem, etc.) exceed 12 inches (302 mm), ESFR Sprinklers shall be installed in each channel formed by the structural members.

**Ceiling Slope:** Maximum 2 inch rise for 12 inch run (16.7%).

**Building Heights, Storage Heights, and Commodity:** Refer to Table A.

**Maximum Coverage Area:** 100 ft<sup>2</sup> (9,3 m<sup>2</sup>). In some cases, the installation standards permit a greater coverage area.

**Minimum Coverage Area:** 80 ft<sup>2</sup> (7,4 m<sup>2</sup>) per NFPA 13, and 64 ft<sup>2</sup> (5,8 m<sup>2</sup>) per FM 2-2

**Maximum Spacing:** 12 feet (3,7 m) for building heights up to 30 feet (9,1 m), and 10 feet (3,1 m) for building heights greater than 30 feet (9,1 m).

**Minimum Spacing:** 8 feet (2,4 m).

**Minimum Clearance To Commodity:** 36 inches (914 mm).

**NFPA 13 — Deflector To Ceiling Distance:**

ESFR-1 (K=14.0) Pendent: 6 to 14 inches (152 to 356 mm).

ESFR-17 (K=16.8) Pendent: 6 to 14 inches (152 to 356 mm).

ESFR-25 (K=25.2) Pendent: 6 to 18 inches (152 to 457 mm).

**FM 2-2 — Deflector To Ceiling Distance:**

ESFR-17 (K=16.8) Upright: 5 to 14 inches (121 to 356 mm).

ESFR-1 (K=14.0) Pendent: 5 to 14 inches (121 to 356 mm).

ESFR-17 (K=16.8) Pendent: 5 to 14 inches (121 to 356 mm).

**FM 2-2 — Thermal Sensing Element To Ceiling Distance:**

ESFR-17 (K=16.8) Upright: 4 to 13 inches (102 to 330 mm).

ESFR-1 (K=14.0) Pendent: 4 to 13 inches (102 to 330 mm).

ESFR-17 (K=16.8) Pendent: 4 to 13 inches (102 to 330 mm).

ESFR-25 (K=25.2) Pendent: 4 to 18 inches (102 to 457 mm).

**Obstructions Below Upright ESFR Sprinklers (Including Branchlines):**

Per the requirements of FM, obstructions below upright ESFR Sprinklers can be ignored as follows:

- Open-web bar joists or trusses having chords no more than 4 inches (102 mm) wide,
- Bridging or wind bracing no more than 4 inches (102 mm) wide,
- Individual pipes and conduit 4 inches (102 mm) diameter or less (i.e. 3 inch (DN80) pipe size or less will not require sprigs), or
- Individual groups of smaller pipe or conduit having a total width of 4 inches or less.

**TABLE A  
BUILDING HEIGHTS, STORAGE HEIGHTS, AND COMMODITY  
(See Design Criteria Section)**

Open frame (i.e. no solid shelves) single, double, multiple-row, or portable rack storage of Class I - IV and Group A or B plastics	See Table A-1 (Refer to NFPA 13 or FM 8-9 and 2-2 for details)							
Solid pile or palletized storage of Class I - IV and Group A or B plastics	See Table A-2 (Refer to NFPA 13 or FM 8-9 and 2-2 for details)							
Idle pallet storage	See Table A-3 (Refer to NFPA 13 or FM 8-24 and 2-2 for details)							
Rubber Tire Storage	See Table A-4 (Refer to NFPA 13 or FM 8-3 and 2-2 for details)							
Rolled Paper Storage (See Standard)	ESFR-17 UPRIGHT K = 16.8		Comparison to Other TFP ESFR Sprinklers					
			ESFR-1 PENDENT K = 14.0 See Data Sheet TFP318		ESFR-17 PENDENT K = 16.8 See Data Sheet TFP315		ESFR-25 PENDENT K = 25.2 See Data Sheet TFP312	
	NFPA	FM	NFPA	FM	NFPA	FM	NFPA	FM
	-	8-21	13	8-21	13	-	13	8-21
	-	-	30	7-29	-	-	30	-
Flammable Liquid Storage (See Standard)	-	-	30B	7-31	30B	-	30B	7-31
Automotive Components in Portable Racks (Control Mode Only, See Standard)	-	-	-	-	-	-	13	-

**TABLE A-1  
RACK STORAGE  
(See Design Criteria Section)**

Commodity	Maximum Building Height, Feet (m)	Maximum Storage Height, Feet (m)	Minimum Flow Pressure, PSI (BAR)							
			ESFR-17 UPRIGHT K = 16.8		Comparison to Other TFP ESFR Sprinklers					
					ESFR-1 PENDENT K = 14.0 See Data Sheet TFP318		ESFR-17 PENDENT K = 16.8 See Data Sheet TFP315		ESFR-25 PENDENT K = 25.2 See Data Sheet TFP312	
					NFPA	FM	NFPA	FM	NFPA	FM
Class I, Class II, Class III, and Class IV Encapsulated or Unencapsulated -and- Cartoned Unexpanded Plastics	45 (13,7)	40 (12,2)	-	-	90* (6,2)	90* (6,2)	63* (4,3)	63* (4,3)	40 (2,8)	50 (3,4)
	40 (12,2)	35 (10,7)	-	-	75 (5,2)	75 (5,2)	52 (3,6)	52 (3,6)	25 (1,7)	40 (2,8)
	35 (10,7)	30 (9,1)	-	52 (3,6)	75 (5,2)	75 (5,2)	52 (3,6)	52 (3,6)	20 (1,4)	30 (2,1)
	32 (9,7)	25 (7,6)	-	42 (2,9)	60 (4,1)	60 (4,1)	42 (2,9)	42 (2,9)	20 (1,4)	30 (2,1)
	30 (9,1)	25 (7,6)	-	35 (2,4)	50 (3,4)	50 (3,4)	35 (2,4)	35 (2,4)	15 (1,0)	20 (1,4)
Uncartoned (Exposed) Unexpanded Plastics	45 (13,7)	40 (12,2)	-	-	90* (6,2)	90* (6,2)	63* (4,3)	63* (4,3)	-	-
	40 (12,2)	35 (10,7)	-	-	75 (5,2)	75 (5,2)	52 (3,6)	52 (3,6)	-	50 (3,4)
	32 (9,7)	25 (7,6)	-	-	60 (4,1)	60 (4,1)	42 (2,9)	42 (2,9)	-	50 (3,4)
	30 (9,1)	25 (7,6)	-	-	50 (3,4)	50 (3,4)	35 (2,4)	35 (2,4)	-	50 (3,4)
Cartoned Expanded Plastics	32 (9,7)	25 (7,6)	-	42 (2,9)	60 (4,1)	60 (4,1)	42 (2,9)	42 (2,9)	-	-
	30 (9,1)	25 (7,6)	-	35 (2,4)	50 (3,4)	50 (3,4)	35 (2,4)	35 (2,4)	-	-
Uncartoned (Exposed) Expanded Plastics	30 (9,1)	25 (7,6)	-	-	-	100 (6,8)	-	-	-	-
	25 (7,6)	20 (6,1)	-	-	-	75 (5,2)	-	-	-	-

\* One level of in-rack sprinklers is required.

**TABLE A-2  
PALLETIZED AND SOLID PILED STORAGE  
(See Design Criteria Section)**

Commodity	Maximum Building Height, Feet (m)	Maximum Storage Height, Feet (m)	Minimum Flow Pressure, PSI (BAR)							
			ESFR-17 UPRIGHT K = 16.8		Comparison to Other TFP ESFR Sprinklers					
					ESFR-1 PENDENT K = 14.0 See Data Sheet TFP318		ESFR-17 PENDENT K = 16.8 See Data Sheet TFP315		ESFR-25 PENDENT K = 25.2 See Data Sheet TFP312	
					NFPA	FM	NFPA	FM	NFPA	FM
Class I, Class II, Class III, and Class IV Encapsulated or Unencapsulated -and- Cartoned Unexpanded Plastics	45 (13,7)	40 (12,2)	-	-	-	-	-	-	40 (2,8)	50 (3,4)
	45 (13,7)	35 (10,7)	-	-	-	90 (6,2)	-	-	40 (2,8)	50 (3,4)
	40 (12,2)	35 (10,7)	-	-	75 (5,2)	75 (5,2)	52 (3,6)	52 (3,6)	25 (1,7)	40 (2,8)
	35 (10,7)	30 (9,1)	-	52 (3,6)	75 (5,2)	75 (5,2)	52 (3,6)	52 (3,6)	20 (1,4)	30 (2,1)
	32 (9,7)	25 (7,6)	-	42 (2,9)	60 (4,1)	60 (4,1)	42 (2,9)	42 (2,9)	20 (1,4)	30 (2,1)
	30 (9,1)	25 (7,6)	-	35 (2,4)	50 (3,4)	50 (3,4)	35 (2,4)	35 (2,4)	15 (1,0)	20 (1,4)
Uncartoned (Exposed) Unexpanded Plastics	45 (13,7)	35 (10,7)	-	-	-	90 (6,2)	-	-	-	-
	40 (12,2)	35 (10,7)	-	-	75 (5,2)	75 (5,2)	52 (3,6)	52 (3,6)	-	50 (3,4)
	32 (9,7)	25 (7,6)	-	-	60 (4,1)	60 (4,1)	42 (2,9)	42 (2,9)	-	50 (3,4)
	30 (9,1)	25 (7,6)	-	-	50 (3,4)	50 (3,4)	35 (2,4)	35 (2,4)	-	50 (3,4)
Cartoned Expanded Plastics	32 (9,7)	25 (7,6)	-	42 (2,9)	60 (4,1)	60 (4,1)	42 (2,9)	42 (2,9)	-	-
	30 (9,1)	25 (7,6)	-	35 (2,4)	50 (3,4)	50 (3,4)	35 (2,4)	35 (2,4)	-	-
Uncartoned (Exposed) Expanded Plastics	40 (12,2)	25 (7,6)	-	-	-	-	-	-	-	60 (4,1)
	30 (9,1)	25 (7,6)	-	-	-	100 (6,8)	-	-	-	60 (4,1)
	25 (7,6)	20 (6,1)	-	-	-	75 (5,2)	-	-	-	60 (4,1)

**TABLE A-3  
IDLE PALLET STORAGE  
(See Design Criteria Section)**

Type and Arrangement	Maximum Building Height, Feet (m)	Maximum Storage Height, Feet (m)	Minimum Flow Pressure, PSI (BAR)							
			ESFR-17 UPRIGHT K = 16.8		Comparison to Other TFP ESFR Sprinklers					
					ESFR-1 PENDENT K = 14.0 See Data Sheet TFP318		ESFR-17 PENDENT K = 16.8 See Data Sheet TFP315		ESFR-25 PENDENT K = 25.2 See Data Sheet TFP312	
					NFPA	FM	NFPA	FM	NFPA	FM
Wood or Plastic In-rack -and- Plastic on Floor	40 (12,2)	35 (10,7)	-	-	75 (5,2)	75 (5,2)	52 (3,6)	52 (3,6)	-	50 (3,4)
	32 (9,7)	25 (7,6)	-	-	60 (4,1)	60 (4,1)	42 (2,9)	42 (2,9)	-	50 (3,4)
	30 (9,1)	25 (7,6)	-	-	50 (3,4)	50 (3,4)	35 (2,4)	35 (2,4)	-	50 (3,4)
Wood on Floor	40 (12,2)	35 (10,7)	-	-	75 (5,2)	75 (5,2)	52 (3,6)	52 (3,6)	-	50 (3,4)
	35 (10,7)	20 (6,1)	-	52 (3,6)	75 (5,2)	75 (5,2)	52 (3,6)	52 (3,6)	-	50 (3,4)
	32 (9,7)	25 (7,6)	-	-	60 (4,1)	60 (4,1)	42 (2,9)	42 (2,9)	-	50 (3,4)
	32 (9,7)	20 (6,1)	-	42 (2,9)	60 (4,1)	60 (4,1)	42 (2,9)	42 (2,9)	-	50 (3,4)
	30 (9,1)	25 (7,6)	-	-	50 (3,4)	50 (3,4)	35 (2,4)	35 (2,4)	-	50 (3,4)
	30 (9,1)	20 (6,1)	-	35 (2,4)	50 (3,4)	50 (3,4)	35 (2,4)	35 (2,4)	-	50 (3,4)

**TABLE A-4  
RUBBER TIRE STORAGE  
(See Design Criteria Section)**

Piling Method	Maximum Building Height, Feet (m)	Maximum Storage Height, Feet (m)	Minimum Flow Pressure, PSI (BAR)							
			ESFR-17 UPRIGHT K = 16.8		Comparison to Other TFP ESFR Sprinklers					
					ESFR-1 PENDENT K = 14.0 See Data Sheet TFP318		ESFR-17 PENDENT K = 16.8 See Data Sheet TFP315		ESFR-25 PENDENT K = 25.2 See Data Sheet TFP312	
NFPA *	FM	NFPA	FM	NFPA	FM	NFPA	FM	NFPA	FM	
On-Side or On-Tread in Palletized Portable Racks, Open Portable Racks, or Fixed Racks without Solid Shelves	30 (9,1)	25 (7,6)	—	35 (2,4)	50 (3,5)	50 (3,5)	35 (2,4)	35 (2,4)	15 (1,0)	20 (1,4)
On-Side in Palletized Portable Racks, Open Portable Racks, or Fixed Racks without Solid Shelves	35 (10,7)	25 (7,6)	—	—	75 (5,2)	—	52 (3,6)	—	25 (1,7)	—
Laced Tires in Open Portable Steel Racks	30 (9,1)	25 (7,6)	—	—	75 (5,2)	—	52 (3,6)	—	—	—
On-Side in Palletized Portable Racks	40 (12,2)	25 (7,6)	—	—	75 (5,2)	—	52 (3,6)	—	—	—

\* UL Listed as an equivalency to K14 ESFR protection

## Operation

The fusible link assembly is comprised of two link halves that are joined together by a thin layer of solder. When the rated temperature is reached, the solder melts and the two link halves separate activating the sprinkler and allowing water to flow.

## Installation

The Model ESFR-17 Upright Sprinklers are to be installed in accordance with the following instructions:

**NOTE**

*Damage to the fusible Link Assembly during installation can be avoided by handling the sprinkler by the frame arms only (i.e., do not apply pressure to the fusible Link Assembly), and by using the appropriate sprinkler wrench. Damaged sprinklers must be replaced.*

*A leak tight 3/4 inch NPT sprinkler joint should be obtained with a torque of 10 to 20 ft.lbs. (13,4 to 26,8 Nm). Higher*

*levels of torque may distort the sprinkler inlet with consequent leakage or impairment of the sprinkler.*

**Step 1.** The ESFR-17 Upright Sprinkler must be installed in the upright position.

**Step 2.** With pipe thread sealant applied, hand tighten the sprinkler into the sprinkler fitting. Do not apply pressure to the Link Assembly, and handle the ESFR-17 Sprinkler only by the Frame arms.

**Step 3.** Wrench tighten the ESFR-17 Sprinkler using only the W-Type 21 Sprinkler Wrench (Ref. Figure 2) and by fully engaging (seating) the wrench on the sprinkler wrench flats.

**Step 4.** After installation, inspect the Link Assembly of each ESFR-17 Sprinkler for damage. In particular, verify that the Link Assembly and Hook are positioned as illustrated in Figure 1, and that the Link Assembly has not been bent, creased, or forced out of its normal position in any way.

Damaged sprinklers must be replaced.

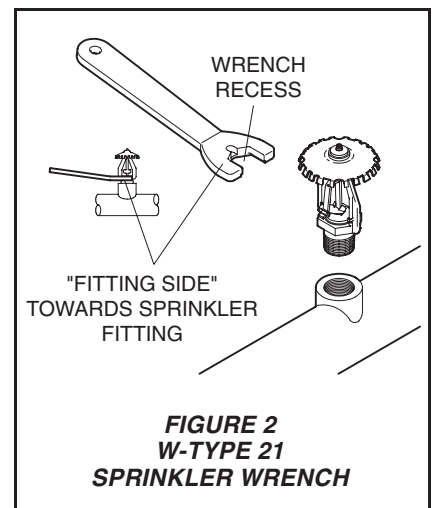

## Care and Maintenance

The Model ESFR-17 must be maintained and serviced in accordance with the following instructions:

**NOTE**

*Before closing a fire protection system main control valve for maintenance work on the fire protection system that it controls, permission to shut down the affected fire protection systems must be obtained from the proper authorities and all personnel who may be affected by this action must be notified.*

Sprinklers that are found to be leaking or exhibiting visible signs of corrosion must be replaced.

Automatic sprinklers must never be painted, plated, coated, or otherwise altered after leaving the factory. Modified or over-heated sprinklers must be replaced.

Care must be exercised to avoid damage - before, during, and after installation. Sprinklers damaged by dropping, striking, wrench twist/slippage, or the like, must be replaced.

The owner is responsible for the inspection, testing, and maintenance of their fire protection system and devices in compliance with this document, as well as with the applicable standards of the National Fire Protection Association (e.g., NFPA 25), in addition to the standards of any other authorities having jurisdiction. The installing contractor or sprinkler manufacturer should be contacted relative to any questions.

It is recommended that automatic sprinkler systems be inspected, tested, and maintained by a qualified Inspection Service in accordance with local requirements and/or national codes.

## Limited Warranty

Products manufactured by Tyco Fire Products are warranted solely to the original Buyer for ten (10) years against defects in material and workmanship when paid for and properly installed and maintained under normal use and service. This warranty will expire ten (10) years from date of shipment by Tyco Fire Products. No warranty is given for products or components manufactured by companies not affiliated by ownership with Tyco Fire Products or for products and components which have been subject to misuse, improper installation, corrosion, or which have not been installed, maintained, modified or repaired in accordance with applicable Standards of the National Fire Protection Association, and/or the standards of any other Authorities Having Jurisdiction. Materials found by Tyco Fire Products to be defective shall be either repaired or replaced, at Tyco Fire Products' sole option. Tyco Fire Products neither assumes, nor authorizes any person to assume for it, any other obligation in connection with the sale of products or parts of products. Tyco Fire Products shall not be responsible for sprinkler system design errors or inaccurate or incomplete information supplied by Buyer or Buyer's representatives.

IN NO EVENT SHALL TYCO FIRE PRODUCTS BE LIABLE, IN CONTRACT, TORT, STRICT LIABILITY OR UNDER ANY OTHER LEGAL THEORY, FOR INCIDENTAL, INDIRECT, SPECIAL OR CONSEQUENTIAL DAMAGES, INCLUDING BUT NOT LIMITED TO LABOR CHARGES, REGARDLESS OF WHETHER TYCO FIRE PRODUCTS WAS INFORMED ABOUT THE POSSIBILITY OF SUCH DAMAGES, AND IN NO EVENT SHALL TYCO FIRE PRODUCTS' LIABILITY EXCEED AN AMOUNT EQUAL TO THE SALES PRICE.

**THE FOREGOING WARRANTY IS MADE IN LIEU OF ANY AND ALL OTHER WARRANTIES EXPRESS OR IMPLIED, INCLUDING WARRANTIES OF MERCHANTABILITY AND FITNESS FOR A PARTICULAR PURPOSE.**

## Ordering Procedure

When placing an order, indicate the full product name. Please specify the Sprinkler Identification Number (SIN), quantity, and temperature rating. Refer to the Price List for complete listing of Part Numbers.

Contact your local distributor for availability.

**Sprinkler Assemblies with NPT Thread Connections:**

Specify: (specify temperature rating), natural brass, TY7126 Upright Sprinkler, P/N (specify).

- 165°F/74°C ..... P/N 58-447-1-165
- 214°F/101°C ..... P/N 58-447-1-214

**Sprinkler Assemblies with ISO Thread Connections:**

Specify: (specify temperature rating), natural brass, TY7126 Upright Sprinkler with ISO pipe thread connection, P/N (specify).

- 165°F/74°C ..... P/N 58-448-1-165
- 214°F/101°C ..... P/N 58-448-1-214

**Sprinkler Wrench**

Specify: W-Type 21 Sprinkler Wrench, P/N 56-001-0-686.