

## Model K17-231 — 16.8 K-factor Upright and Pendent Sprinklers Standard Response, Standard Coverage

### General Description

The 16.8 K-factor, Model K17-231, Standard Response, Standard Coverage, Upright and Pendent Sprinklers (Ref. Figure 1) are automatic sprinklers of the frangible bulb type. They are "standard response - spray sprinklers" which produce a hemispherical water distribution pattern below the deflector.

The 16.8 K-factor, K17-231 Sprinklers were subjected to full scale, high-piled storage, fire tests to qualify their use in lieu of 8.0 or 11.2 K-Factor standard spray sprinklers for the protection of high-piled storage.

Higher flow rates can be achieved at much lower pressures with the 16.8 K-factor, K17-231 Sprinklers — making their use highly advantageous in high density applications, such as the protection of high-piled storage.

Applications for the 16.8 K-factor, Model K17-231 Pendent and Upright Sprinklers are expanding beyond the current listings/approvals. For information regarding research fire tests which may be acceptable to an Authority Having Jurisdiction, please contact the Technical Services Department.

#### WARNING

The 16.8 K-factor, Model K17-231 Up-

#### IMPORTANT

Always refer to Technical Data Sheet TFP700 for the "INSTALLER WARNING" that provides cautions with respect to handling and installation of sprinkler systems and components. Improper handling and installation can permanently damage a sprinkler system or its components and cause the sprinkler to fail to operate in a fire situation or cause it to operate prematurely.

right and Pendent Sprinklers described herein must be installed and maintained in compliance with this document, as well as with the applicable standards of the National Fire Protection Association, in addition to the standards of any other authorities having jurisdiction. **Failure to do so may impair the performance of these devices.**

The owner is responsible for maintaining their fire protection system and devices in proper operating condition. The installing contractor or manufacturer should be contacted with any questions.

### Sprinkler Identification Number

TY7151 - Upright, 16.8K  
TY7251 - Pendent, 16.8K

TY7151 is a redesignation for C7151, G1888, and S8040.

TY7251 is a redesignation for C7251, G1889, and S8041.

### Technical Data

#### Approvals

UL and C-UL Listed. FM and NYC Approved. (Specific details for laboratory listings and approvals given in Table A. The approvals apply to the service conditions indicated in the Design Criteria section.)

**Maximum Working Pressure**  
175 psi (12,1 bar)

**Pipe Thread Connection**  
3/4 inch NPT or ISO 7-R3/4

**Discharge Coefficients**  
K = 16.8 GPM/psi<sup>1/2</sup>  
(241,9 LPM/bar<sup>1/2</sup>)



#### Temperature Ratings

Refer to Table A

#### Finish

Natural Brass

#### Physical Characteristics

Frame	.....	Bronze
Button	.....	Bronze
Sealing Assembly	.....	Beryllium Nickel w/Teflon†
Bulb	.....	Glass (5 mm dia.)
Compression Screw	.....	Brass
Deflector	.....	Brass

†Registered trademark of DuPont.

			SPRINKLER FINISH
TYPE	TEMP.	BULB LIQUID	NATURAL BRASS
UPRIGHT K=16.8 (TY7151)	155°F/68°C	Red	1, 2, 3, 4
	200°F/93°C	Green	
	286°F/141°C	Blue	
PENDENT K=16.8 (TY7251)	155°F/68°C	Red	1, 2, 4
	200°F/93°C	Green	
	286°F/141°C	Blue	

**NOTES:**

1. Listed by Underwriters Laboratories, Inc. (UL Listed).
2. Listed by by Underwriters Laboratories, Inc. for use in Canada (C-UL Listed).
3. Approved by Factory Mutual Research Corporation (FM Approved).
4. Approved by the City of New York K under MEA 177-03-E.

**TABLE A  
LABORATORY LISTINGS AND APPROVALS  
(Refer to the Design Criteria Section)**

## Design Criteria

### UL and C-UL Listing Requirements

The 16.8 K-factor, Model K17-231 (TY7151 & TY7251) Sprinklers may be installed in accordance with NFPA 13 standard sprinkler position and area/density flow calculation requirements for light, ordinary, or extra hazard occupancies with a minimum residual (flowing) pressure of 7 psi (0,5 bar) in wet or dry pipe sprinkler systems, or they may be installed in accordance with NFPA 13 standard sprinkler position and area/density flow calculation requirements for high piled storage occupancies (solid piled, palletized, rack storage, bin box, and shelf storage including but not limited to Class I-IV and Group A plastics) with a minimum residual (flowing) pressure of 7 psi (0,5 bar) for wet or dry pipe systems.

The following two examples are typical of the types of arrangements permitted by NFPA 13. For all combinations of lesser and greater building heights, lesser and greater storage heights, storage arrangements, commodity classifications, and lesser or greater required design densities, refer to NFPA 13 for specifics.

*Example 1: NFPA 13 provides ceiling only protection (i.e., no in-rack sprinklers) criteria using open frame (i.e. no solid shelves) single, double, multiple-row, or portable rack storage (without the need for in-rack sprinkler protection) of cartoned or uncartoned unexpanded Group A or B plastics, or, car-*

*toned expanded Group A or B plastics, with:*

- a storage height of up to 20 feet (6,1 m);
- a maximum ceiling height of 27 feet (8,2 m);
- a minimum deflector to top of storage clearance of 18 inches (457 mm);
- a minimum design density of 0.60 gpm/ft<sup>2</sup> (24,4 mm/min);
- a minimum residual (flowing) pressure of 7 psi (0,5 bar);
- a minimum design area of 2000 ft<sup>2</sup> (186 m<sup>2</sup>) for wet systems or 2600 ft<sup>2</sup> (242 m<sup>2</sup>) for dry pipe systems

*Example 2: NFPA 13 provides ceiling only protection (i.e., no in-rack sprinklers) criteria using open frame (i.e. no solid shelves) single, double, multiple-row, or portable rack storage (without the need for in-rack sprinkler protection) of cartoned or uncartoned unexpanded Group A or B plastics, or, cartoned expanded Group A or B plastics, with:*

- a storage height of up to 25 feet (7,6 m);
- a maximum ceiling height of 30 feet (9,1 m);
- a minimum deflector to top of storage clearance of 18 inches (457 mm);
- a minimum design density of 0.80 gpm/ft<sup>2</sup> (32,6 mm/min);
- a minimum residual (flowing) pressure of 7 psi (0,5 bar);

- a minimum design area” of 2000 ft<sup>2</sup> (186 m<sup>2</sup>) for wet systems or 4500 ft<sup>2</sup> (418 m<sup>2</sup>) for dry pipe systems

### FM Approval Requirements

The 16.8 K-factor, Model K17-231 (TY7151) Upright Sprinklers may be installed in accordance with the applicable “control mode density/area” guidelines provided by Factory Mutual. (FM guidelines may differ from UL and C-UL Listing criteria.)

## Operation

The glass bulb contains a fluid that expands when exposed to heat. When the rated temperature is reached, the fluid expands sufficiently to shatter the glass bulb, allowing the sprinkler to activate and flow water.

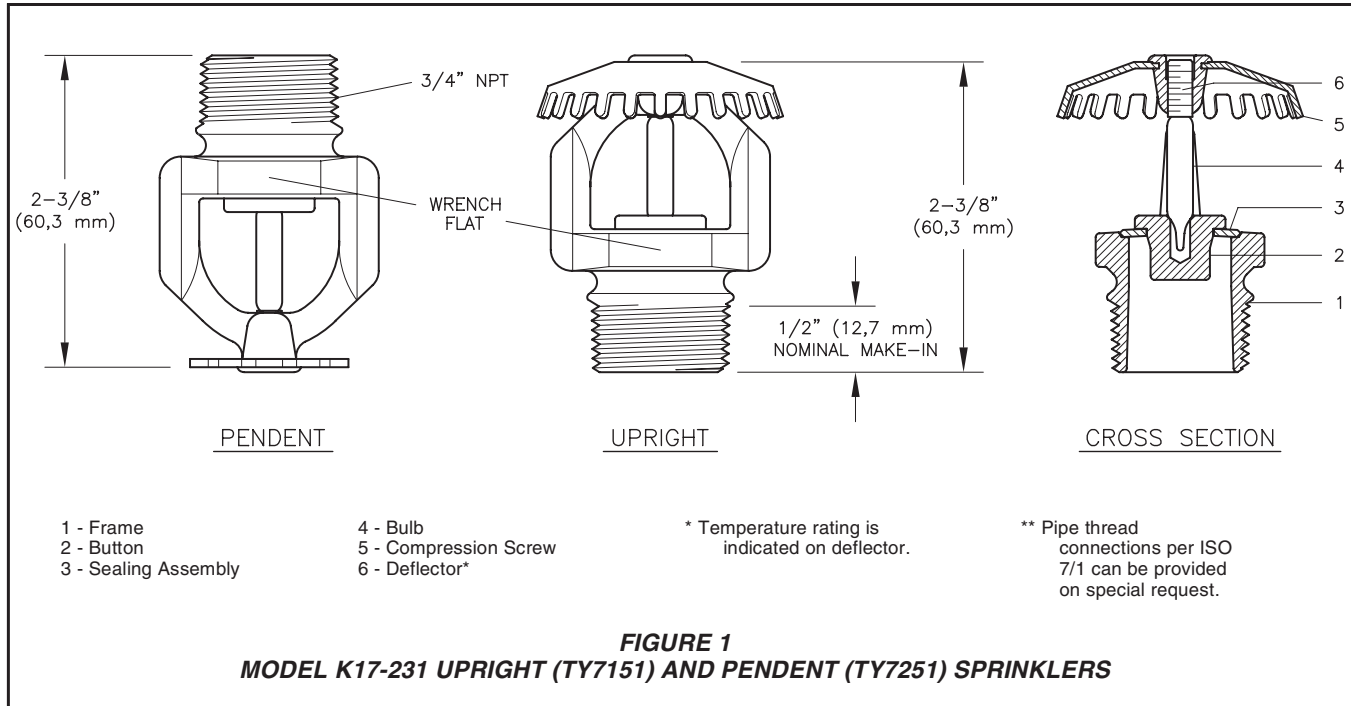

## Installation

### NOTE

Do not install any bulb type sprinkler if the bulb is cracked or there is a loss of liquid from the bulb. With the sprinkler held horizontal, a small air bubble should be present. The diameter of the air bubble is approximately 1/16 inch (1,6 mm) for the 155°F/68°C to 3/32 inch (2,4 mm) for the 286°F/141°C rating.

The Model K17-231 Sprinklers must be installed in accordance with the following instructions.

1. With pipe thread sealant applied to the pipe threads, hand tighten the Model K17-231 Sprinkler into the sprinkler fitting.
2. Using the W-Type 8 Sprinkler Wrench (Ref. Fig. 2) applied to the sprinkler Wrench Flats (Ref. Fig. 1), tighten the Model K17-231 Sprinkler into the sprinkler fitting.

### NOTE

A leak tight 3/4 inch NPT sprinkler joint should be obtained with a torque of 10 to 20 ft.lbs. (13,4 to 26,8 Nm). Higher levels of torque may distort the sprinkler inlet with consequent leakage or impairment of the sprinkler.

## Care and Maintenance

The Model K17-231 Sprinklers must be maintained and serviced in accordance with the following instructions:

### NOTE

Before closing a fire protection system main control valve for maintenance work on the fire protection system that it controls, permission to shut down the affected fire protection systems must be obtained from the proper authorities and all personnel who may be affected by this action must be notified.

Sprinklers that are found to be leaking or exhibiting visible signs of corrosion must be replaced.

Automatic sprinklers must never be painted, plated, coated, or otherwise altered after leaving the factory. Modified sprinklers must be replaced. Sprinklers that have been exposed to corrosive products of combustion, but have not operated, should be replaced if they cannot be completely cleaned by wiping the sprinkler with a cloth or by brushing it with a soft bristle brush.

Care must be exercised to avoid damage to the sprinklers - before, during, and after installation. Sprinklers damaged by dropping, striking, wrench twist/slippage, or the like, must be replaced. Also, replace any sprinkler that has a cracked bulb or that has lost liquid from its bulb. (Ref. Installation Section).

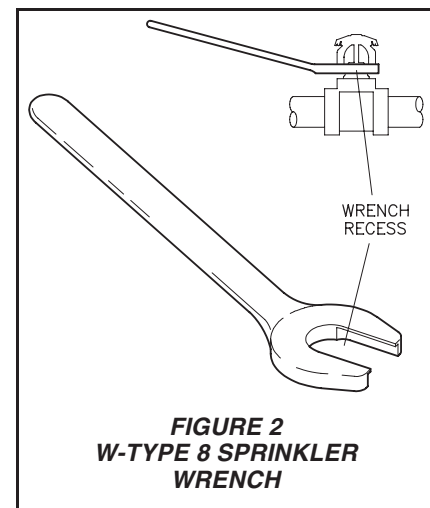

The owner is responsible for the inspection, testing, and maintenance of their fire protection system and devices in compliance with this document, as well as with the applicable standards of the National Fire Protection Association (e.g., NFPA 25), in addition to the standards of any other authorities having jurisdiction. The installing contractor or sprinkler manufacturer should be contacted relative to any questions.

It is recommended that automatic sprinkler systems be inspected, tested, and maintained by a qualified Inspection Service in accordance with local requirements and/or national codes.

## Limited Warranty

Products manufactured by Tyco Fire Products are warranted solely to the original Buyer for ten (10) years against defects in material and workmanship when paid for and properly installed and maintained under normal use and service. This warranty will expire ten (10) years from date of shipment by Tyco Fire Products. No warranty is given for products or components manufactured by companies not affiliated by ownership with Tyco Fire Products or for products and components which have been subject to misuse, improper installation, corrosion, or which have not been installed, maintained, modified or repaired in accordance with applicable Standards of the National Fire Protection Association, and/or the standards of any other Authorities Having Jurisdiction. Materials found by Tyco Fire Products to be defective shall be either repaired or replaced, at Tyco Fire Products' sole option. Tyco Fire Products neither assumes, nor authorizes any person to assume for it, any other obligation in connection with the sale of products or parts of products. Tyco Fire Products shall not be responsible for sprinkler system design errors or inaccurate or incomplete information supplied by Buyer or Buyer's representatives.

IN NO EVENT SHALL TYCO FIRE PRODUCTS BE LIABLE, IN CONTRACT, TORT, STRICT LIABILITY OR UNDER ANY OTHER LEGAL THEORY, FOR INCIDENTAL, INDIRECT, SPECIAL OR CONSEQUENTIAL DAMAGES, INCLUDING BUT NOT LIMITED TO LABOR CHARGES, REGARDLESS OF WHETHER TYCO FIRE PRODUCTS WAS INFORMED ABOUT THE POSSIBILITY OF SUCH DAMAGES, AND IN NO EVENT SHALL TYCO FIRE PRODUCTS' LIABILITY EXCEED AN AMOUNT EQUAL TO THE SALES PRICE.

**THE FOREGOING WARRANTY IS MADE IN LIEU OF ANY AND ALL OTHER WARRANTIES EXPRESS OR IMPLIED, INCLUDING WARRANTIES OF MERCHANTABILITY AND FITNESS FOR A PARTICULAR PURPOSE.**

## Ordering Procedure

When placing an order, indicate the full product name. Please specify the Sprinkler Identification Number (SIN), quantity, and temperature rating. Refer to the Price List for complete listing of Part Numbers.

Contact your local distributor for availability.

### Sprinkler Assemblies with NPT Thread Connections:

Specify: (specify SIN), 16.8 K-factor, Model K17-231,(specify temperature rating), (specify Pendent or Upright) Sprinkler, P/N (specify).

#### Upright (SIN TY7151)

155°F/68°C ..... PSN 51-888-1-155  
 200°F/93°C ..... PSN 51-888-1-200  
 286°F/141°C ..... PSN 51-888-1-286

#### Pendent (SIN TY7251)

155°F/68°C ..... PSN 51-889-1-155  
 200°F/93°C ..... PSN 51-889-1-200  
 286°F/141°C ..... PSN 51-889-1-286

#### Sprinkler Wrench:

Specify: W-Type 8 Sprinkler Wrench, P/N 56-892-1-001.