

Ultra K17 — 16.8 K-factor Upright Specific Application Control Mode Sprinkler Standard Response, 155°F/68°C & 200°F/93°C

General Description

The 16.8 K-factor, Ultra K17, 155°F/68°C & 200°F/93°C, Standard Response, Upright Specific Application Control Mode Sprinklers (Ref. Figure 1) are automatic sprinklers of the frangible bulb type. They are intended for use with National Fire Protection Association and Factory Mutual Research Corporation "specific application control mode" installation criteria for the protection of high piled storage. The Ultra K17 Sprinklers can provide a higher level of protection than standard spray sprinklers and, in some cases, they can provide an economical advantage by eliminating in-rack sprinklers.

Applications for the Ultra K17 Upright Specific Application Control Mode Sprinklers are expanding beyond the current "specific application" listings/approvals. For information regarding research fire tests which may be acceptable to an Authority Having Jurisdiction, please contact the Technical Services Department.

WARNING

The 16.8 K-factor, Ultra K17 Upright Specific Application Control Mode Sprinklers described herein must be installed and maintained in compli-

IMPORTANT

Always refer to Technical Data Sheet TFP700 for the "INSTALLER WARNING" that provides cautions with respect to handling and installation of sprinkler systems and components. Improper handling and installation can permanently damage a sprinkler system or its components and cause the sprinkler to fail to operate in a fire situation or cause it to operate prematurely.

ance with this document, as well as with the applicable standards of the National Fire Protection Association, in addition to the standards of any other authorities having jurisdiction. **Failure to do so may impair the performance of these devices.**

The owner is responsible for maintaining their fire protection system and devices in proper operating condition. The installing contractor or manufacturer should be contacted with any questions.

Sprinkler Identification Number

TY7153

TY7153 is a redesignation for C7153, G1887, and S8042.

Technical Data

Approvals

UL and C-UL Listed. FM and NYC Approved. (Specific details for laboratory listings and approvals given in Table A. The approvals apply to the service conditions indicated in the Design Criteria section.)

Maximum Working Pressure

175 psi (12,1 bar)

Pipe Thread Connection

3/4 inch NPT or ISO 7-R3/4

Discharge Coefficients

K = 16.8 GPM/psi^{1/2}
(241,9 LPM/bar^{1/2})

Temperature Ratings

155°F/68°C and 200°F/93°C

Finish

Natural Brass



Physical Characteristics

Frame	Bronze
Button	Bronze
Sealing Assembly	
	Beryllium Nickel w/Teflon†
Bulb	Glass (5 mm dia.)
Compression Screw	
	Brass
Deflector	Chrome Plated Brass

†Registered trademark of DuPont.

TYPE	TEMP.	BULB LIQUID	SPRINKLER FINISH
			NATURAL BRASS w/ CHROME DEFLECTOR
UPRIGHT K=16.8 (TY7153)	155°F/68°C	Red	3, 4
	200°F/93°C	Green	1, 2, 3, 4

NOTES:

1. Listed by Underwriters Laboratories, Inc. (UL Listed).
2. Listed by Underwriters Laboratories, Inc. for use in Canada (C-UL Listed).
3. Approved by Factory Mutual Research Corporation (FM Approved).
4. Approved by the City of New York under MEA 177-03-E.

TABLE A
LABORATORY LISTINGS AND APPROVALS
(Refer to the Design Criteria Section)

Design Criteria

UL and C-UL Listing Requirements

Ultra K17 (TY7153) Sprinklers with a 200°F/93°C temperature rating may be installed in accordance with NFPA 13 “Specific Application Control Mode Sprinkler (for Storage Use)” requirements to provide ceiling only protection (i.e., no in-rack sprinklers) for high piled storage occupancies (Solid-piled, palletized and rack storage including but not limited to Class I-IV and Group A plastics) using the following criteria:

- a storage height of up to 25 feet (7,6 m);
- a maximum ceiling height of 30 feet (9,1 m);
- a minimum deflector to top of storage clearance of 36 inches (0,9m);
- a maximum coverage area of 100 ft² (9,1 m²);
- a minimum coverage area of 80 ft² (7,3 m²);
- NFPA spacing criteria for large drop sprinklers, i.e.
 - 12 feet (3,6 m) maximum for unobstructed construction,
 - 10 feet (3,0 m) maximum for rack storage applications,
 - 10 feet (3,0 m) maximum for obstructed construction, and
 - 8 feet (2,4 m) minimum;
- NFPA deflector-to-ceiling distances for large drop sprinklers;
- NFPA obstruction criteria for large drop sprinklers;

- no additional column protection is required;
- a hydraulic design of:
 - 15 sprinklers at 10 psi (0,7 bar) for Class I & II commodities, or
 - 15 sprinklers at 22 psi (1,5 bar) for Class III, IV, and cartoned or uncartoned unexpanded Group A and B plastics; and,
- wet systems only (including preaction systems that qualify as wet-pipe systems)

FM Approval Requirements

The 16.8 K-factor, Ultra K17 (TY7153) Sprinklers may be installed with the applicable “specific application control mode” guidelines provided by Factory Mutual. (FM guidelines may differ from UL and C-UL Listing criteria.)

Operation

The glass bulb contains a fluid that expands when exposed to heat. When the rated temperature is reached, the fluid expands sufficiently to shatter the glass bulb, allowing the sprinkler to activate and flow water.

Installation

NOTE

Do not install any bulb type sprinkler if the bulb is cracked or there is a loss of liquid from the bulb. With the sprinkler held horizontal, a small air bubble should be present. The diameter of the air bubble is approximately 1/16 inch (1,6 mm).

The Ultra K17 Sprinklers must be installed in accordance with the following instructions:

Step 1. With pipe thread sealant applied to the pipe threads, hand tighten the Ultra K17 Sprinkler into the sprinkler fitting.

Step 2. Using the W-Type 8 Sprinkler Wrench (Ref. Fig. 2) applied to the sprinkler Wrench Flats (Ref. Fig. 1), tighten the Ultra K17 Sprinkler into the sprinkler fitting.

NOTE

A leak tight 3/4 inch NPT sprinkler joint should be obtained with a torque of 10 to 20 ft.lbs. (13,4 to 26,8 Nm). Higher levels of torque may distort the sprinkler inlet with consequent leakage or impairment of the sprinkler.

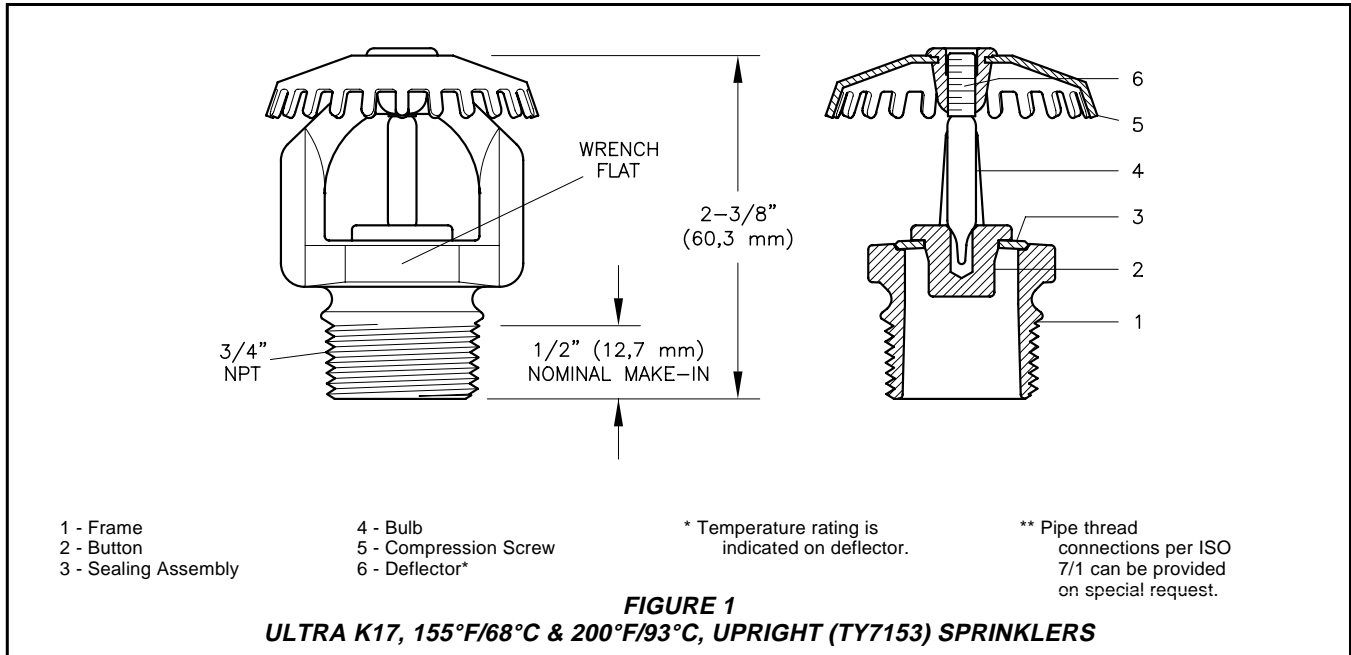

Care and Maintenance

The Ultra K17 Sprinklers must be maintained and serviced in accordance with the following instructions:

NOTE

Before closing a fire protection system main control valve for maintenance work on the fire protection system that it controls, permission to shut down the affected fire protection systems must be obtained from the proper authorities and all personnel who may be affected by this action must be notified.

Sprinklers that are found to be leaking or exhibiting visible signs of corrosion must be replaced.

Automatic sprinklers must never be painted, plated, coated, or otherwise altered after leaving the factory. Modified sprinklers must be replaced. Sprinklers that have been exposed to corrosive products of combustion, but have not operated, should be replaced if they cannot be completely cleaned by wiping the sprinkler with a cloth or by brushing it with a soft bristle brush.

Care must be exercised to avoid damage to the sprinklers - before, during, and after installation. Sprinklers damaged by dropping, striking, wrench twist/slippage, or the like, must be replaced. Also, replace any sprinkler that has a cracked bulb or that has lost liquid from its bulb. (Ref. Installation Section).

The owner is responsible for the in-

spection, testing, and maintenance of their fire protection system and devices in compliance with this document, as well as with the applicable standards of the National Fire Protection Association (e.g., NFPA 25), in addition to the standards of any other authorities having jurisdiction. The installing contractor or sprinkler manufacturer should be contacted relative to any questions.

It is recommended that automatic sprinkler systems be inspected, tested, and maintained by a qualified Inspection Service in accordance with local requirements and/or national codes.

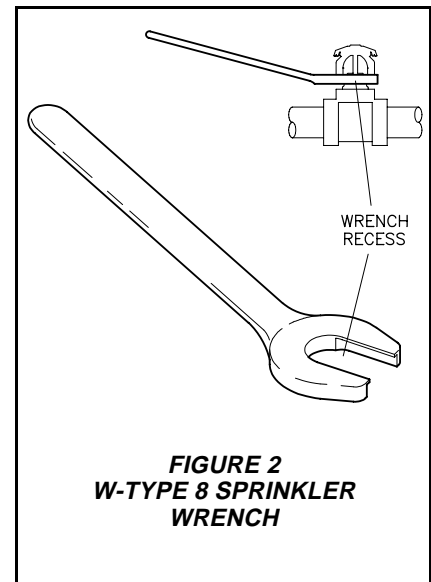

Limited Warranty

Products manufactured by Tyco Fire & Building Products (TFBP) are warranted solely to the original Buyer for ten (10) years against defects in material and workmanship when paid for and properly installed and maintained under normal use and service. This warranty will expire ten (10) years from date of shipment by TFBP. No warranty is given for products or components manufactured by companies not affiliated by ownership with TFBP or for products and components which have been subject to misuse, improper installation, corrosion, or which have not been installed, maintained, modified or repaired in accordance with applicable Standards of the National Fire Protection Association, and/or the standards of any other Authorities Having Jurisdiction. Materials found by TFBP to be defective shall be either repaired or replaced, at TFBP's sole option. TFBP neither assumes, nor authorizes any person to assume for it, any other obligation in connection with the sale of products or parts of products. TFBP shall not be responsible for sprinkler system design errors or inaccurate or incomplete information supplied by Buyer or Buyer's representatives.

In no event shall TFBP be liable, in contract, tort, strict liability or under any other legal theory, for incidental, indirect, special or consequential damages, including but not limited to labor charges, regardless of whether TFBP was informed about the possibility of such damages, and in no event shall TFBP's liability exceed an amount equal to the sales price.

The foregoing warranty is made in lieu of any and all other warranties, express or implied, including warranties of merchantability and fitness for a particular purpose.

This limited warranty sets forth the exclusive remedy for claims based on failure of or defect in products, materials or components, whether the claim is made in contract, tort, strict liability or any other legal theory.

This warranty will apply to the full extent permitted by law. The invalidity, in whole or part, of any portion of this warranty will not affect the remainder.

Ordering Procedure

When placing an order, indicate the full product name. Please specify the Sprinkler Identification Number (SIN), quantity, and temperature rating. Refer to the Price List for complete listing of Part Numbers.

Contact your local distributor for availability.

Sprinkler Assemblies with NPT Thread Connections:

Specify: (specify SIN), 16.8 K-factor, Ultra K17, (specify temperature rating), Upright Specific Application Control Mode Sprinkler, P/N (specify).

Upright (SIN TY7153)

155°F/68°C PSN 51-887-1-155
200°F/93°C PSN 51-887-1-200

Sprinkler Wrench:

Specify: W-Type 8 Sprinkler Wrench, P/N 56-892-1-001.