

## Preaction System with Model DV-1 Deluge Valve Single Interlock, Supervised 4 and 6 Inch (DN100 and DN150)

### General Description

The 4 and 6 inch (DN100 and DN150) Supervised Single Interlock Preaction System (Ref. Figure 1) utilizes the Model DV-1 External Resetting Deluge Valve described in Technical Data Sheet TFP1330. Actuation of the system can be initiated by wet pilot, dry pilot, or electric detection as described in TFP1330, and supervision of the sprinkler piping is provided with the Preaction Trim (Ref. Figure 2) that is used in conjunction with the Model CV-2 Swing Check Valve described in TFP1560. No priming water is required for use with this Preaction Trim.

The Supervised Single Interlock Preaction System utilizes automatic sprinklers and a supplemental heat detection system (Ref. Figures 3A, 3B, and 3C). Actuation of the detection system automatically operates (releases) the DV-1 Deluge Valve, which in turn permits water to flow into the sprinkler piping system and to be discharged from any sprinklers that may be open.

In accordance with the requirements of the National Fire Protection Association, a preaction system employing more than 20 automatic sprinklers is to have the sprinkler piping automatically supervised to monitor the overall pressure retention integrity of the system. In the case of the 4 and 6 inch (DN100 and DN150) Supervised Single Interlock Preaction System, the Model CV-2 Swing Check Valve provides an air check so that the system can be automatically pressurized with a nominal supervisory air or nitrogen pressure of 10 psi (0,69 bar). A supervisory low pressure alarm switch which is set to transfer its contacts at nominally 5 psi (0,34 bar), on decreasing pressure, is then utilized to indicate whether there are any abnormal leaks in the sprinkler system piping. Loss of air pressure from the system as a result of a damaged sprinkler or broken

Valve Size	Nominal Installation Dimensions in Inches and (mm)							
	A	B	C	D	E	F	G	H
4 (100)	23.25 (590,6)	3.50 (88,9)	8.69 (220,7)	12.00 (304,8)	14.56 (369,8)	13.69 (347,7)	2.34 (59,4)	7.56 (192,0)
6 (150)	26.25 (666,8)	3.00 (76,2)	8.69 (220,7)	12.00 (304,8)	15.44 (392,2)	14.50 (368,3)	2.34 (59,4)	8.44 (214,4)

**NOTES:**

- (1) Minimum clearance, additional 2" (500 mm) is recommended.
- (2) Refer to Technical Data Sheet TFP1330 for additional installation dimensions.

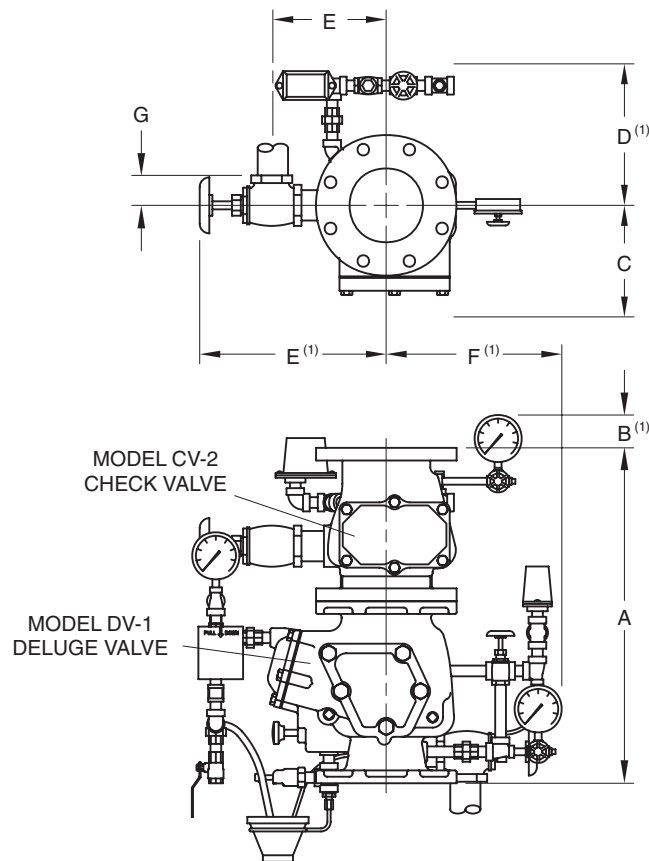

**FIGURE 1**  
**4 and 6 INCH (DN100 and DN150) SUPERVISED SINGLE INTERLOCK**  
**PREACTION SYSTEM RISER ARRANGEMENT**

pipng will not cause the DV-1 Valve to open — the air pressure is for supervision only.

Typically, the system designer selects the detection components for a preaction system which will respond to a fire sooner than the automatic sprinklers. In these cases, the system will experience only a minimal delay in water delivery over that for a wet pipe sprinkler system, since the system will have begun to fill with water before a sprinkler operates.

In addition to being used for detecting a break in the system piping that might impair water delivery in the event of a fire, supervised single interlock preaction systems are also used to protect areas where there is danger of serious water damage which might result from damaged automatic sprinklers or piping. Typically, such areas include computer rooms, storage areas for valuable artifacts, libraries, archives, and areas subject to freezing.

Also, preaction systems are effectively used to protect properties where a pre-alarm of a possible fire condition may allow time for fire extinguishment by alternate suppression means, prior to the need for a sprinkler discharge. In the event the fire cannot otherwise be extinguished, the preaction sprinkler system will then perform as the primary fire protection system.

#### WARNING

*The Model DV-1 Supervised Single Interlock Preaction System described herein must be installed and maintained in compliance with this document, as well as with the applicable standards of the National Fire Protection Association, in addition to the standards of any other authorities having jurisdiction. Failure to do so may impair the performance of the related devices.*

*The owner is responsible for maintaining their fire protection system and devices in proper operating condition. The installing contractor or manufacturer should be contacted with any questions.*

## Technical Data

### Approvals

UL and C-UL Listed.  
FM Approved (electric actuation only).

### Deluge Valve

Model DV-1.

### Riser Check Valve

Model CV-2.

### Working Pressure Range

20 to 175 psi (1,4 to 12,1 bar).

### Valve Trim

The trim for the Supervised Single Interlock Preaction System (TFP1330 plus Fig. 2) forms a part of the laboratory listings and approvals. The trim is necessary for proper operation of the DV-1 Valve.

Each package of trim includes the following items:

- Water Supply Pressure Gauge
- Diaphragm Chamber Pressure Gauge
- Diaphragm Chamber Connections
- Manual Control Station
- Main Drain Valve
- System Drain Valve
- Alarm Test Valve
- Automatic Drain Valve
- System Air Pressure Gauge
- Air Supply Connections
- Low Air Pressure Supervisory Switch
- Waterflow Pressure Alarm Switch

The Preaction Trim (Ref. Fig. 2) is provided with galvanized or black nipples and fittings. The galvanized trim is intended for non-corrosive or corrosive conditions, whereas the black trim is principally intended for use with AFFF systems.

### System Design Considerations

The automatic sprinklers, as well as the electric fire control panel (automatic control unit), fire detection devices, manual pull stations, and signaling devices, as applicable, which are utilized with the Supervised Single Interlock Preaction System must be UL Listed, ULC or C-UL Listed, or FM Approved, as applicable.

In order for a single interlock preaction system to be hydraulically calculated as a wet pipe system, as opposed to a dry pipe sprinkler system, the detection system must be designed to oper-

ate sooner than the automatic sprinklers on the sprinkler piping.

In planning the installation, consideration must also be given to the disposal of the relatively large quantities of water that may be associated with draining the system or performing a flow test.

#### NOTES

*Approval by Factory Mutual is contingent on the use of an FM Approved 24VDC Solenoid Valve (P/N 52-287-1-024). FM only approves solenoid valves for use in non-hazardous locations.*

*Consult with the Authority Having Jurisdiction regarding installation criteria pertaining to electric actuation circuitry.*

### System Air Pressure Requirements

The supervisory air (nitrogen) pressure is to be 10 plus or minus 2 psi (0,69 plus or minus 0,07 bar). The use of a higher supervisory pressure is subject to approval by the Authority Having Jurisdiction, and it should be understood that the use of a higher supervisory pressure may increase water delivery time. The use of a lower supervisory pressure may prevent clearing the alarm of the Supervisory Low Pressure Alarm Switch (Item 16 - Fig. 2), which is factory set to alarm at 5 plus or minus 1 psi (0,34 plus or minus 0,07 bar) on decreasing pressure. The supervisory air supply pressure of 10 plus or minus 2 psi (0,69 plus or minus 0,07 bar) can be provided by any of the following methods. Refer to the applicable data sheet for laboratory approval information.

- Model G16AC812 (self contained) Automatic Supervisory Air Supply described in Technical Data Sheet TFP1620.
- A maximum 200 psi (13,8 bar) plant air supply in combination with the Model AMD-1 Air Maintenance Device described in Technical Data Sheet TFP1221.
- A maximum 3000 psi (206,9 bar) nitrogen cylinder in combination with the Model AMD-3 Nitrogen Maintenance Device described in Technical Data Sheet TFP1241.

#### NOTE

*The dew point of the air or nitrogen supply, for a system exposed to freezing conditions, must be maintained below the lowest ambient temperature to which the system piping will be exposed. Introduction of moisture into the system piping can create ice build*



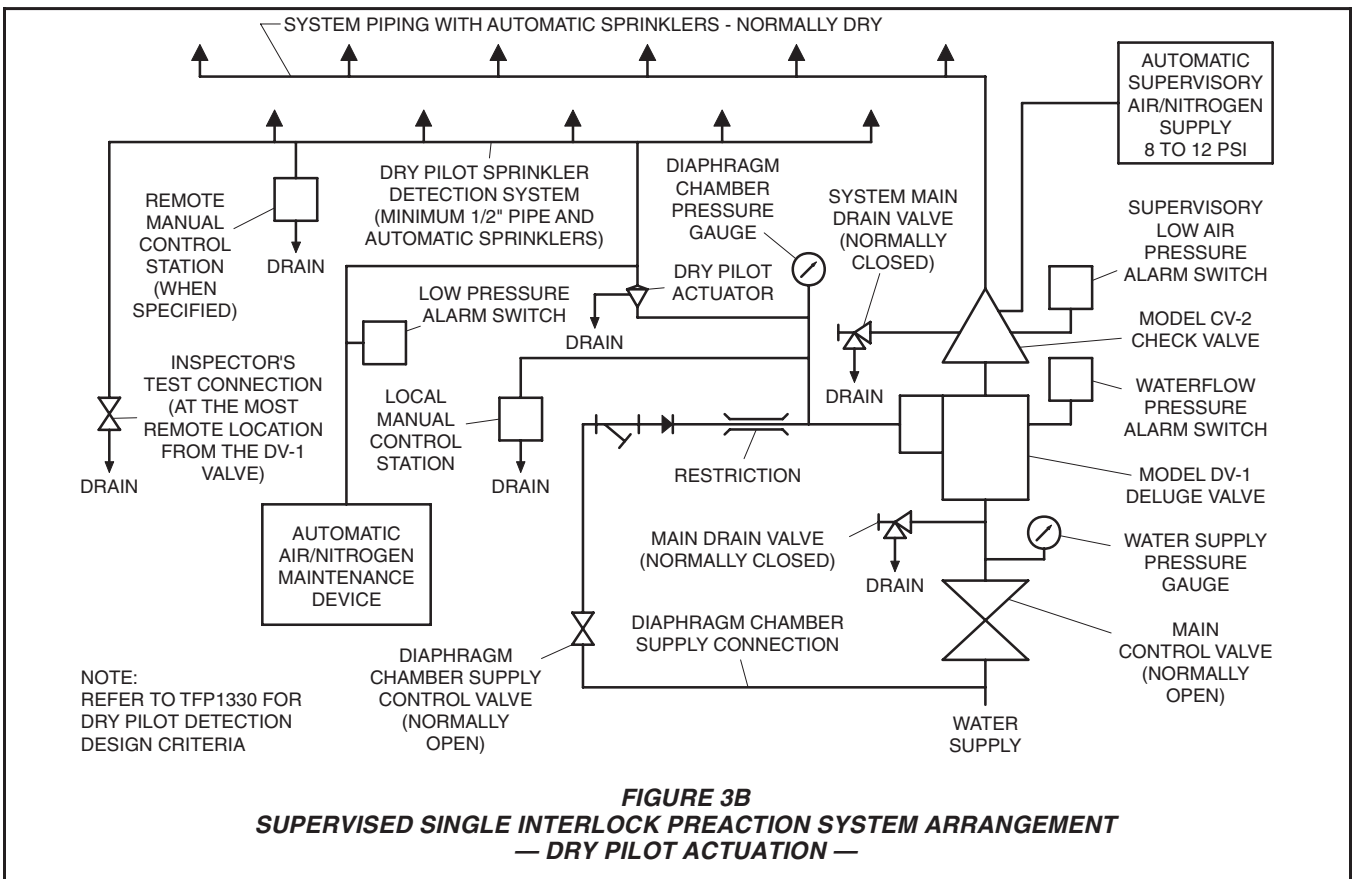
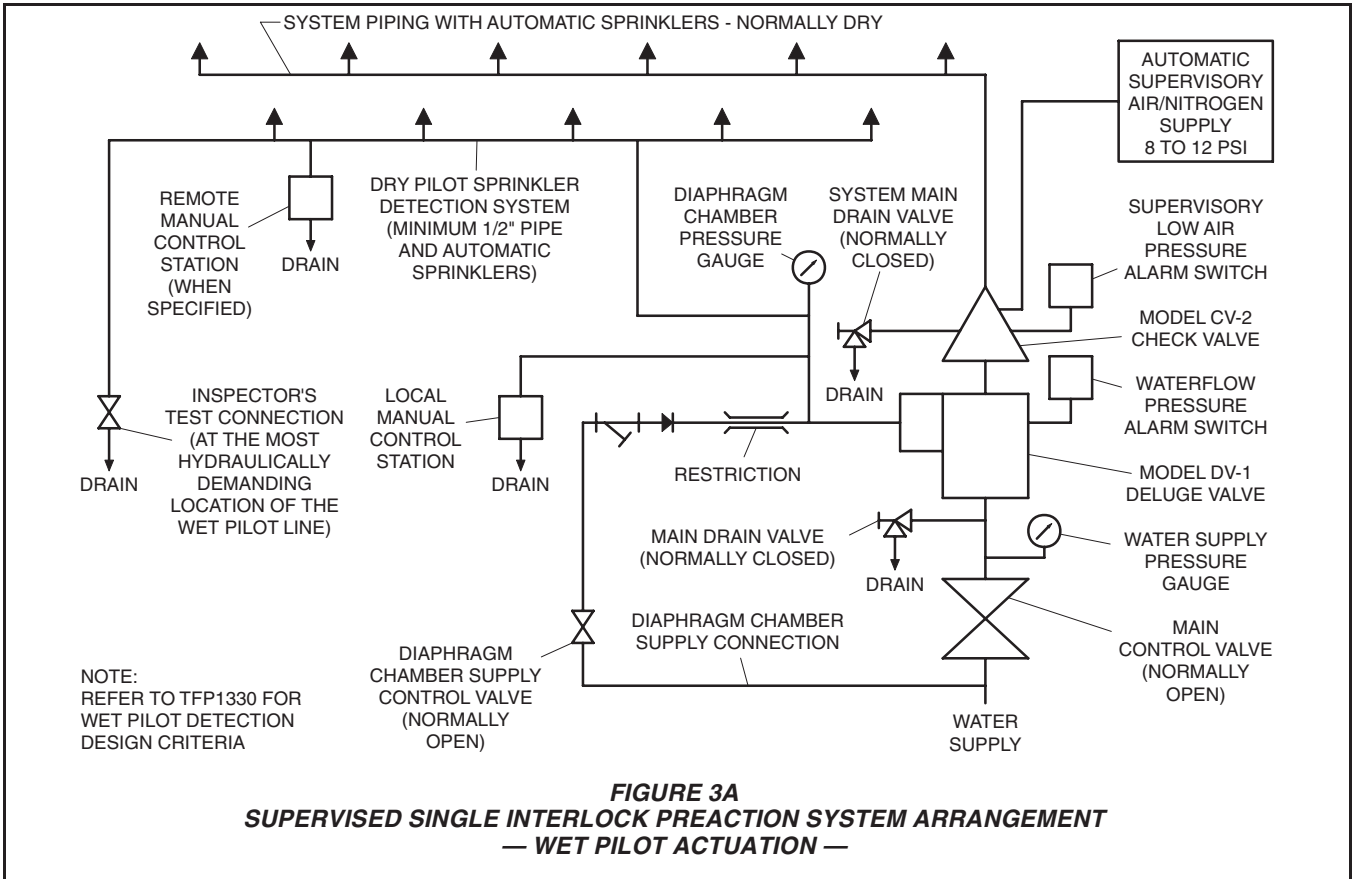

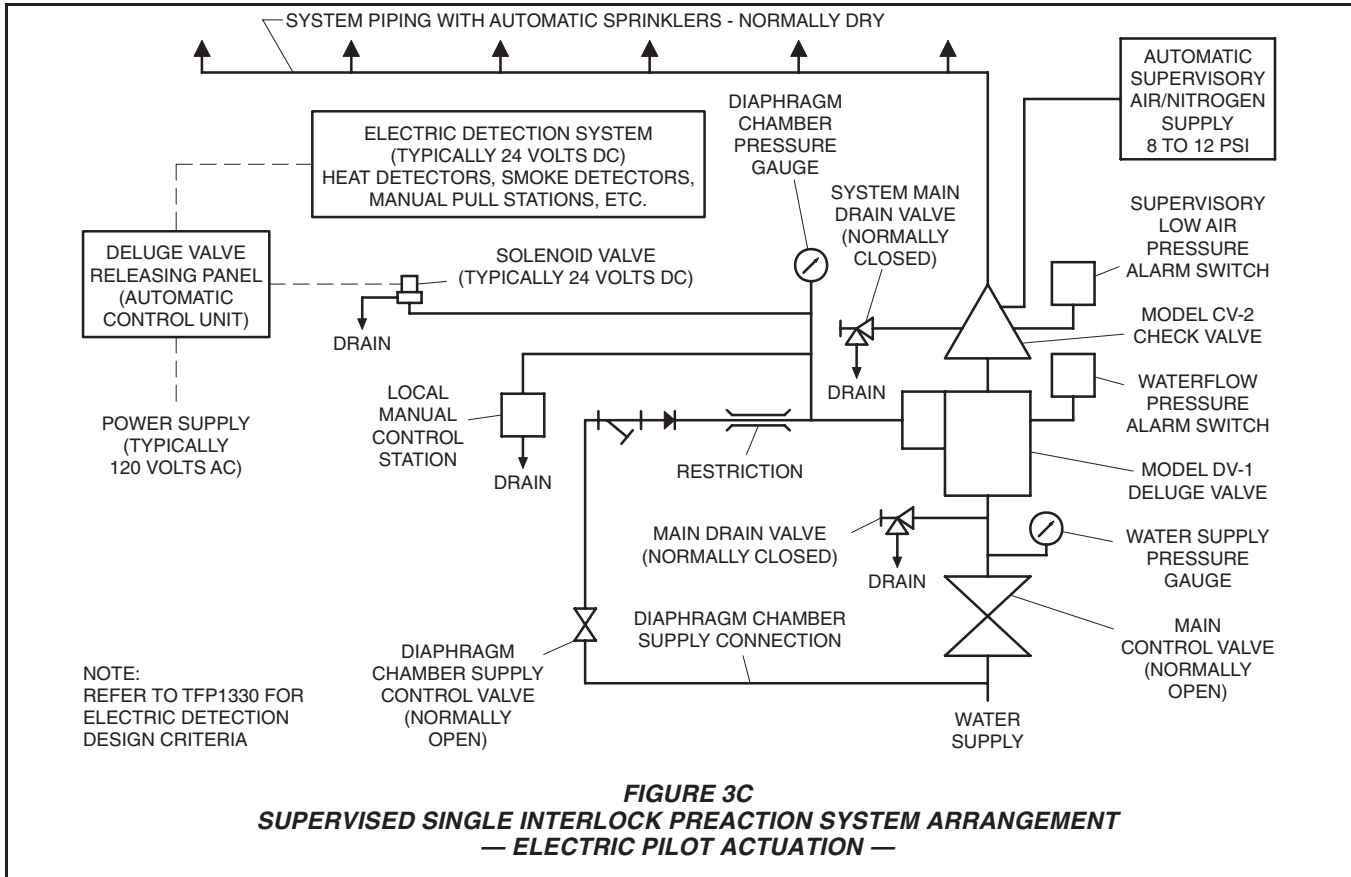

## Installation

### NOTES

Proper operation of the Model DV-1 Deluge Valves depends upon their trim being installed in accordance with the instructions given in this Technical Data Sheet, as well as TFP1330. Failure to follow the appropriate trim diagram may prevent the DV-1 Valve from functioning properly, as well as void listings, approvals, and the manufacturer's warranties.

The DV-1 Valve must be installed in a readily visible and accessible location.

The DV-1 Valve and associated trim must be maintained at a minimum temperature of 40°F/4°C.

Heat tracing of the DV-1 Valve or its associated trim is not permitted. Heat tracing can result in the formation of hardened mineral deposits that are capable of preventing proper operation.

The Model DV-1 Deluge Valve is to be installed in accordance with the following criteria:

**Step 1.** All nipples, fittings, and devices must be clean and free of scale and burrs before installation. Use pipe

thread sealant sparingly on male pipe threads only.

**Step 2.** The DV-1 Valve must be trimmed in accordance with Technical Data Sheet TFP1330.

**Step 3.** The Preaction Trim must be installed in accordance with Figure 2.

The grooved end elbow fitting and couplings are to be installed in accordance with standard Grinnell installation practices.

Care must be taken to ensure that check valves, strainers, globe valves, etc. are installed with the flow arrows in the proper direction.

Drain tubing to the drip funnel must be installed with smooth bends that will not restrict flow.

**Step 4.** Suitable provision must be made for disposal of drain water. Drainage water must be directed such that it will not cause accidental damage to property or danger to persons.

**Step 5.** A suitable automatic supervisory air (nitrogen) supply, as described in the Technical Data Section, is to be installed in accordance with the applicable Technical Data Sheet and set for 10 plus or minus 2 psi (0,69 plus or minus 0,14 bar).

**Step 6.** A desiccant dryer, when required for the supervisory air supply, is to be installed between a drip leg and the Model AMD-1 Air Maintenance Device or between the Model G16AC812 Automatic Supervisory Air Supply and the Preaction Trim.

**Step 7.** The Supervisory Low Pressure Alarm Switch is to be wired to the supervisory alarm initiating circuit of an alarm panel.

**Step 8.** All conduit and electrical connections are to be made in accordance with the requirements of the authority having jurisdiction and/or the National Electric Code.

## System Setting Procedure

Steps 1 through 6 are to be performed when initially setting the system; after an operational test of the system; or, after system operation due to a fire. Refer to Technical Data Sheet TFP1330 as necessary.

**Step 1.** Close the Diaphragm Chamber Supply Control Valve in the Diaphragm Chamber Supply Connection to the DV-1 Valve.

**Step 2.** Close the Main Control Valve, and close the Supervisory Air Supply Control Valve. If the system is equipped with dry pilot actuation, close the Air Supply Control Valve to the dry pilot line.

**Step 3.** Open the Main Drain Valve for the DV-1 Valve, the Main Drain Valve for the CV-2 Check Valve, and all auxiliary drains. Close the auxiliary drain valves after water ceases to discharge.

**Step 4.** Reset the DV-1 Valve and open the Main Control Valve in accordance with Technical Data Sheet TFP1330.

**Step 5.** Close the Main Drain Valve for the CV-2 Check Valve.

**Step 6.** Open the Supervisory Air Supply Control Valve and allow the system supervisory pressure of 10 plus or minus 2 psi (0,69 plus or minus 0,07 bar) to be established at which point the Supervisory Low Pressure Alarm Switch should return to its "normal" condition.

### NOTE

*After setting a fire protection system, notify the proper authorities and advise those responsible for monitoring proprietary and/or central station alarms.*

## In Case Of Low Supervisory Pressure Alarm

### NOTE

*Before closing a fire protection system main control valve for maintenance work on the fire protection system which it controls, permission to shut down the affected fire protection systems must first be obtained from the proper authorities and all personnel who may be affected by this decision must be notified.*

**Step 1.** Close the Diaphragm Chamber Supply Control Valve in the Diaphragm Chamber Supply Connection to the DV-1 Valve.

**Step 2.** Close the Main Control Valve, open the Main Drain Valve for the DV-1 Valve, and close the Supervisory Air Supply Control Valve.

**Step 3.** Determine/correct the cause for the loss of supervisory pressure.

**Step 4.** Reset the system in accordance with the System Setting Procedure section.

## Care and Maintenance

The following procedures, inspections, and maintenance must be performed as indicated, in addition to any specific requirements of the NFPA, and any impairment must be immediately corrected.

The owner is responsible for the inspection, testing, and maintenance of their fire protection system and devices in compliance with this document, as well as with the applicable standards of the National Fire Protection Association (e.g., NFPA 25), in addition to the standards of any authority having jurisdiction. The installing contractor or product manufacturer should be contacted relative to any questions.

It is recommended that automatic sprinkler systems be inspected, tested, and maintained by a qualified Inspection Service in accordance with local requirements and/or national codes.

### NOTES

*Some of the procedures outlined in this section will result in operation of the associated alarms. Consequently, notification must first be given to the owner and the fire department, central station, or other signal station to which the alarms are connected.*

*Before closing a fire protection system main control valve for maintenance work on the fire protection system that it controls, permission to shut down the affected fire protection systems must first be obtained from the proper authorities and all personnel who may be affected by this action must be notified.*

### Quarterly Supervisory Low Pressure Alarm Test Procedure

Proper operation of the Supervisory Low Pressure Alarm Switch should be performed quarterly as follows:

**Step 1.** Crack open the Main Drain Valve for the CV-2 Check Valve (Item 6, Figure 2) to slowly relieve supervisory air pressure from the system. Verify that the Supervisory Low Pressure Alarm Switch is operational and that the low pressure set point is approximately 5 psi (0,34 bar).

**Step 2.** Close the Main Drain Valve (Item 6, Figure 2) and allow the system supervisory pressure of nominally 10 plus or minus 2 psi (0,69 0,14 bar) be automatically re-established. The Supervisory Low Pressure Alarm Switch should return to its "normal" condition.

### Model DV-1 Deluge Valve Test Procedures

The following list of test procedures as outlined in Technical Data Sheet TFP1330 should be performed at the indicated intervals:

- Annual Operation Test Procedure
- Five Year Internal Valve Inspection
- Quarterly Waterflow Alarm Test Procedure
- Quarterly Solenoid Valve Test Procedure For Electric Actuation
- Quarterly Dry Pilot Actuator Test Procedure For Dry Pilot Actuation
- Quarterly Low Pressure Alarm Test Procedure And Condensate Drain Procedure For Dry Pilot Actuation

### Pressure Relief Valve Maintenance

Over pressurization of the system piping with air will result in the opening of the Pressure Relief Valve (Item 3, Fig. 2). If the Relief Valve continues to bleed air after the system pressure has been reduced to its normal supervisory pressure range of 10 plus or minus 2 psi (0,69 plus or minus 0,07 bar), most likely debris became lodged in the seating area. To help clean the seating area, slowly pull up on the ring at the top of the Relief Valve to allow a full flow of air through the Relief Valve, and then release the ring to allow the Relief Valve to snap closed. Repeat the cleaning procedure as necessary.

## Limited Warranty

Products manufactured by Tyco Fire Products are warranted solely to the original Buyer for ten (10) years against defects in material and workmanship when paid for and properly installed and maintained under normal use and service. This warranty will expire ten (10) years from date of shipment by Tyco Fire Products. No warranty is given for products or components manufactured by companies not affiliated by ownership with Tyco Fire Products or for products and components which have been subject to misuse, improper installation, corrosion, or which have not been installed, maintained, modified or repaired in accordance with applicable Standards of the National Fire Protection Association, and/or the standards of any other Authorities Having Jurisdiction. Materials found by Tyco Fire Products to be defective shall be either repaired or replaced, at Tyco Fire Products' sole option. Tyco Fire Products neither assumes, nor authorizes any person to assume for it, any other obligation in connection with the sale of products or parts of products. Tyco Fire Products shall not be responsible for sprinkler system design errors or inaccurate or incomplete information supplied by Buyer or Buyer's representatives.

IN NO EVENT SHALL TYCO FIRE PRODUCTS BE LIABLE, IN CONTRACT, TORT, STRICT LIABILITY OR UNDER ANY OTHER LEGAL THEORY, FOR INCIDENTAL, INDIRECT, SPECIAL OR CONSEQUENTIAL DAMAGES, INCLUDING BUT NOT LIMITED TO LABOR CHARGES, REGARDLESS OF WHETHER TYCO FIRE PRODUCTS WAS INFORMED ABOUT THE POSSIBILITY OF SUCH DAMAGES, AND IN NO EVENT SHALL TYCO FIRE PRODUCTS' LIABILITY EXCEED AN AMOUNT EQUAL TO THE SALES PRICE.

**THE FOREGOING WARRANTY IS MADE IN LIEU OF ANY AND ALL OTHER WARRANTIES EXPRESS OR IMPLIED, INCLUDING WARRANTIES OF MERCHANTABILITY AND FITNESS FOR A PARTICULAR PURPOSE.**

# Ordering Procedure

With reference to Table A, the following items must be ordered separately:

- Deluge Valve
- Check Valve
- Actuation Trim
- Preaction Trim
- Supervisory Air Supply
- Solenoid Valve, as applicable
- Accessories

**Replacement Trim Parts:**

Specify: (description) for use with Model DV-1 Deluge Valve, P/N (see Figure 2).

**DELUGE VALVE (SELECT ONE)**

P/N's are for American Standard Flange, Grooved Connections, and Threaded Ports, For other configurations refer to Technical Data Sheet TFP1330. Specify: (size), Model DV-1 (specify end connection) Deluge Valve, P/N (specify).

4 Inch, Flange x Flange .....	P/N 52-470-1-013
4 Inch, Flange x Groove .....	P/N 52-470-4-613
6 Inch, Flange x Flange .....	P/N 52-470-1-015
6 Inch, Flange x Groove .....	P/N 52-470-4-615

**CHECK VALVE**

P/N's are for American Standard Flange, Grooved Connections, and Threaded Ports. For other configurations refer to Technical Data Sheet TFP1560 for the Model CV-2 Check Valve. Specify: (size, Model CV-2 (specify end connection) Check Valve, P/N (specify).

4 Inch, Flange x Flange .....	P/N 52-520-1-013
4 Inch, Flange x Groove .....	P/N 52-520-1-413
4 Inch, Groove x Groove .....	P/N 52-520-1-113
6 Inch, Flange x Flange .....	P/N 52-520-1-015
6 Inch, Flange x Groove .....	P/N 52-520-1-615
4 Inch, Groove x Groove .....	P/N 52-520-1-115

**ACTUATION TRIM (SELECT ONE)**

Specify: (Description and finish — galvanized is standard) for use with 4 or 6 inch DV-1 Deluge Valve P/N (specify).

Wet Pilot Actuation Trim Galvanized .....	P/N 52-470-2-101
Dry Pilot Actuation Trim Galvanized .....	P/N 52-470-2-102
Electric Actuation Trim Galvanized .....	P/N 52-470-2-103
Wet Pilot Actuation Trim Black .....	P/N 52-470-1-101
Dry Pilot Actuation Trim Black .....	P/N 52-470-1-102
Electric Actuation Trim Black .....	P/N 52-470-1-103

**PREACTION TRIM (SELECT ONE)**

Specify: (specify finish — galvanized is standard) Preaction Trim for 4 or 6 inch Model DV-1 Deluge Valves, P/N (specify).

Galvanized .....	P/N 52-470-2-104
Black .....	P/N 52-470-1-104

**SUPERVISORY AIR SUPPLY (SELECT ONE)**

A device capable of maintaining a nominal system air or nitrogen pressure of nominal 10 psi (0,69 bar) must be separately ordered. Specify: (Specify model and description), P/N (specify).

Model AMD-1 Air Maintenance Device (TFP1221) .....	P/N 52-324-2-002
Model AMD-3 Nitrogen Maintenance Device (TFP1241) .....	P/N 52-328-2-001
Model G16AC812 Automatic Supervisory Air Supply (TFP1620) .....	P/N 52-150-1-001

**SOLENOID VALVE (SELECT FOR ELECTRIC ACTUATION ONLY)**

Specify: 24 VDC, NEMA 2, 4, and 4X, 175 psi, Solenoid Valve, P/N (specify).

175 psi .....	P/N 52-287-1-024
---------------	------------------

**OTHER ACCESSORIES**

See TFP1330 as applicable for type of actuation.

**TABLE A — ORDERING LIST**