

D Absperrarmaturen, Absperrschieber mit nichtsteigender Spindel

F Vannes d'Arrêt, Vannes à Passage Direct à Tige Non Sortante

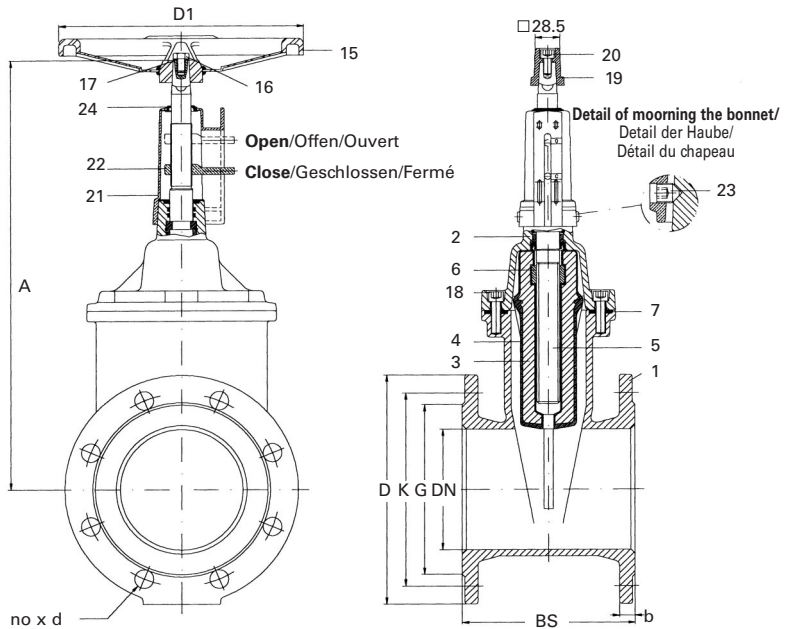

MODEL 05-47 PN10/16



Parts List/Bauteil-Spezifikation/Caractéristiques Techniques

Nr.	Description Umschreibung Description	Material Material Matériau
1	Body/Gehäuse/Corps	GGG-50 Epoxy RAL3000
2	Bonnet/Deckel/Chapeau	GGG-50
3	Wedge/Keil/Siège	GGG-50
4	Wedge Coating/Keilbeschichtung/Revêtement du Siège	NBR
5	Stem/Spindel/Tige	X20 Cr13
6	Wedge Lock Nut/Keilmutter/Ecrou de Verrouillage	Copper Alloy/Kupferlegierung/Alliage de cuivre
7	Gasket/Dichtung/Joint	NBR
8	Packing/Wellendichtring/Chapeau	NBR
9	Circlip/Sicherungsring/Circlip	Steel+Nikum/Stahl+Nikum/Acier + Nikim
10	Gland/Stopfbüchse/Presse-étoupe	P. O.M.
11	Fix ring/Fixiering/Anneau	X12 CrNi 17 7
12	Fix washer/Fixier U-Scheibe/Rondelle	Bronze Rg 5/Bronze Rg 5/Bronze Rg5
13	O Ring/O-Ring/O Ring	NBR
14	Dust Guard/Staubschutz/Capot	NBR
15	Handwheel/Handrad/Volant	Steel/Stahl/Acier
16	Bolt/Schraube/Vis	X5 CrNi 18 10
17	Washer/U-Scheibe/Rondelle	X5 CrNi 18 10
18	Bolt/Schraube/Vis	Steel 8.8/Stahl 8.8/Acier 8.8
19	Square nut/Vierkantschoner/Ecrou Carré	GGG-50
20	Bolt/Schraube/Vis	X5 CrNi 18 10
21	Indicator/Stellungsanzeige/Indicateur	ALSI 13
22	Ind. Wedge/Anzeigeelement/Indicateur du Siège	Copper Alloy/Kupferlegierung/Alliage de cuivre
23	Set Screw/Madenschraube/Jeu de Vis	Stainless Steel/Edelstahl/Acier inox
24	Dust Guard/Staubschutz/Capot	NBR

**Packing detail/
Dichtungsdetail/
Détail de la Garniture**

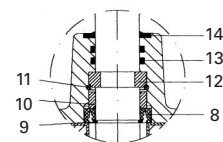

Model 05-47 • RF Flanges/Flansche/Brides PN10/PN16 • Non Rising Stem/Nicht steigende Spindel/Tige Non Sortante

Art. Nr.	DN [Bar]	PN	F4/F5	BS mm	D mm	K mm	G mm	b mm	no x d	A mm	D1 mm	o Kg	Turns to open Umdr. öffnen No tours ouverture	CE	VDS	DVGW	SGGW	OVGW	PAVUS	VNIPO	T/SJU	BM DKF
054710768	65	2.1/2"	10/16	F5	270	185	145	118	19	4 x 19	361	150	16	13	✓	✓	✓	✓	✓	✓	✓	✓
054710898	80	3"	10/16	F5	280	200	160	132	19	8 x 19	390	175	20	16	✓	✓	✓	✓	✓	✓	✓	✓
054711148	100	4"	10/16	F5	300	220	180	156	19	8 x 19	425	200	25	20	✓	✓	✓	✓	✓	✓	✓	✓
054711688	150	6"	10/16	F5	350	285	240	211	19	8 x 23	530	300	45	30	✓	✓	✓	✓	✓	✓	✓	✓
054712197	200	8"	10	F5	400	340	295	266	20	8 x 23	625	350	70	33	✓	✓	✓	✓	✓	✓	✓	✓
054700608G	50	2"	10/16	F4	150	165	125	99	19	4 x 19	324	125	12	13	✓	✓	✓	✓	✓	✓	✓	✓
054700768G	65	2.1/2"	10/16	F4	170	185	145	118	19	4 x 19	361	150	15	13	✓	✓	✓	✓	✓	✓	✓	✓
054700898G	80	3"	10/16	F4	180	200	160	132	19	8 x 19	390	175	19	16	✓	✓	✓	✓	✓	✓	✓	✓
054701148G	100	4"	10/16	F4	190	220	180	156	19	8 x 19	425	200	23	20	✓	✓	✓	✓	✓	✓	✓	✓
054701398G	125	5"	10/16	F4	200	250	210	184	19	8 x 19	488	250	33	25	✓	✓	✓	✓	✓	✓	✓	✓
054701688G	150	6"	10/16	F4	210	285	240	211	19	8 x 23	530	300	41	30	✓	✓	✓	✓	✓	✓	✓	✓
054702198G	200	8"	16	F4	230	340	295	266	20	12 x 23	625	350	63	33	✓	✓	✓	✓	✓	✓	✓	✓
054702738G	250	10"	16	F4	250	400	355	319	22	12 x 28	730	400	92	45	✓	✓	✓	✓	✓	✓	✓	✓
054703248G	300	12"	16	F4	270	455	410	370	25	12 x 28	805	500	130	50	✓	✓	✓	✓	✓	✓	✓	✓
054702197G	200	8"	10	F4	230	340	295	266	20	8 x 23	625	350	63	33	✓	✓	✓	✓	✓	✓	✓	✓
054702737G	250	10"	10	F4	250	400	350	319	22	12 x 23	730	400	92	45	✓	✓	✓	✓	✓	✓	✓	✓
054703247G	300	12"	10	F4	270	455	400	370	25	12 x 23	805	500	130	50	✓	✓	✓	✓	✓	✓	✓	✓

TYCEGFFP-11/03 Tyco reserves the right to change the contents without notice